

**PLANS AND
SPECIFICATIONS**

FOR BUILDING

**STRUCTO
AUTOMOBILE**

No. 12

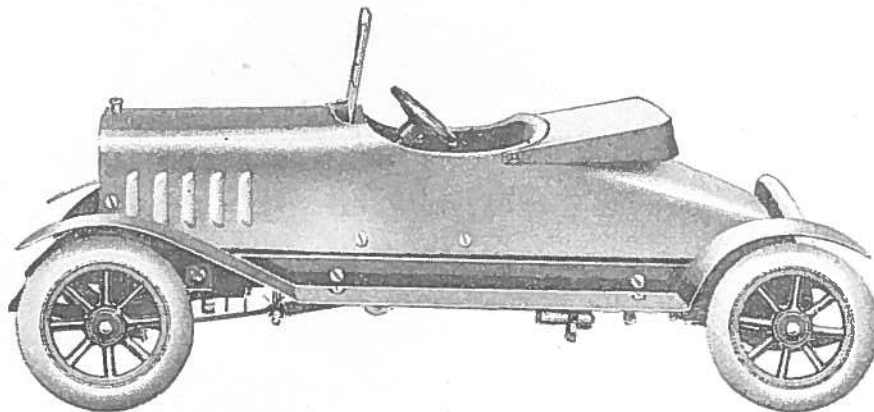

STRUCTO MANUFACTURING COMPANY

FREEPORT, ILLINOIS, U. S. A.

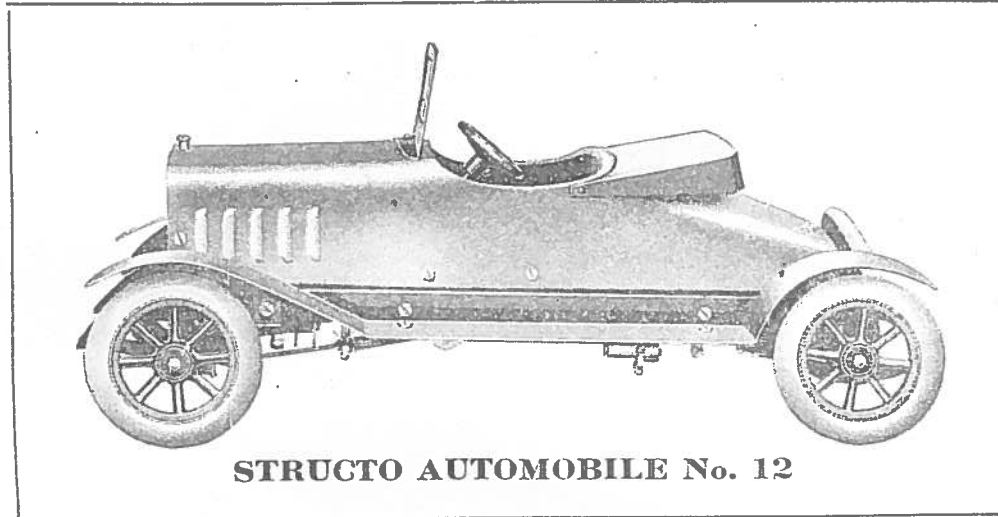

STRUCTO AUTOMOBILE No. 12

THIS OUTFIT contains sufficient material to build a miniature Automobile of the roadster type, very similar in appearance and operation to the latest designs of today.

The following list gives you the mechanical details and features of the Structo Car:

Length of Car (over all).....	16"
Wheel Base.....	12½"
Tread	5½"
Left Hand Drive. Steering device, worm gear type.	
Tires.....	3" x ¾"
Transmission—Selective Sliding Gear Type assembled.	
Two speeds—Forward and reverse. All Gears Structo Die Cast. Complete Differential Gear assembled.	

GENERAL SUGGESTIONS

When "right side" or "left side" of car is mentioned, we mean at your right or left hand as you face the front end of the car from the rear. All drawings in this book are located so that the right hand side of the illustration shows the right-hand side of the car.

The same rules for placing bolts and nuts should be followed as given in all Structo Instruction Books.

There are three sizes of bolts used in this Auto construction as follows:—

- 2, No. 117, ½ inch, round head.
- 2, No. 39, ⅔ inch, called "long bolts."
- 47, No. 40, ¼ inch.

Do not use a different bolt than specified in the instructions; always use the shortest bolts (No. 40) where no instructions are given.

No. 117,
Round Head
Bolt with Nut

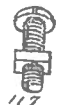

No. 39,
Long Bolt
with Nut



No. 40,
Short Bolt
with Nut



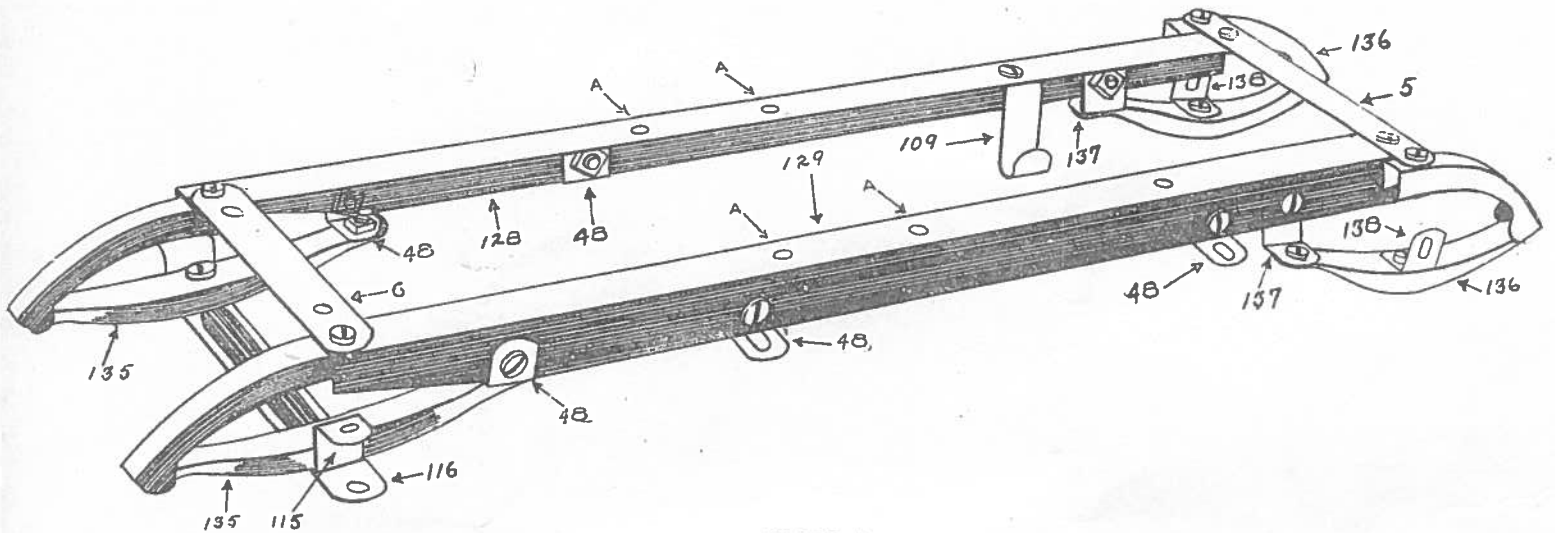

ILLUSTRATION A

Building the Frame Refer to Illustration A

FIRST study the illustration of that part of the Car you are building, and lay out the different parts and compare them with the illustrations. This will prevent you from using the wrong part.

Make a special study of the four different brackets, shown at right of page.

You will note there is very little difference in the shape and size of these, yet they each have a different use in the construction of the Car.

Bolt two front springs No. 135 to front axle pieces 115 and 116 using bolts No. 117. Turn nuts up tight. Bolt brackets 48 to ends of springs. Bolt frame cross member 6 and right frame side member 128 to right front spring as shown. Bolt frame cross member 6 and frame side member 129 in same way. Brackets 48, already attached to springs, should now be bolted to frame side members. Bolt rear cross member 5 to rear ends of frame side members 128 and 129.

Assemble rear springs by fastening rear axle bearing brackets 138 to rear springs 136, in the position shown in illustration. Bolt rear spring bracket 137 (not smaller bracket 48 which has one hole slotted) to springs.

Bolt rear springs 136 to rear cross member 5 and bolt rear spring brackets 137 to frame.

Bolt four fender brackets 48 to frame sides in position shown.

Bolt transmission hanger bracket 109 to frame side member in position shown in illustration.

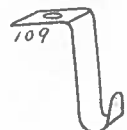
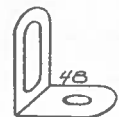
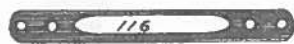
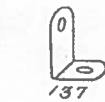
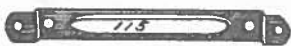
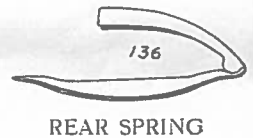

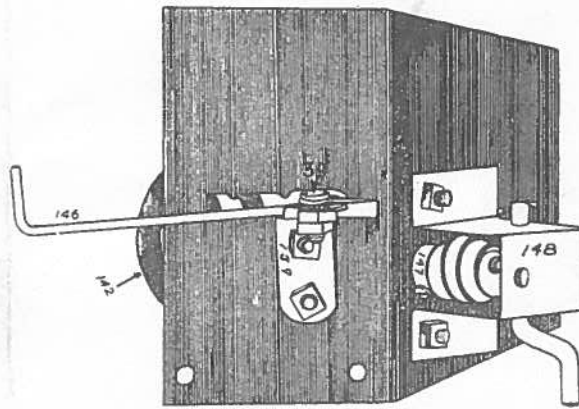

FOOT BOARD—Bottom View

Assembling Control Mechanism on Footboard Refer to Illustration

FROM the under side of footboard 130, thrust steering post 147 through center one of three holes, in tapering section of footboard. Bolt steering gear case 148 to footboard. The end of steering post 147 should rest in hole in steering gear case and worm on end should mesh with teeth of steering gear.

Bolt Control Lever Bracket 139 to under side of Footboard. Insert Control Lever 146 through slot in Footboard and bolt lower end to bracket 139 with long bolt 39. Lock nut this bolt by putting on two nuts. Turn nuts tight.

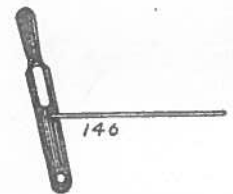
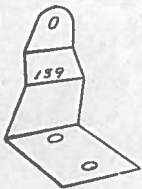
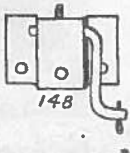
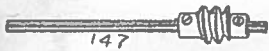
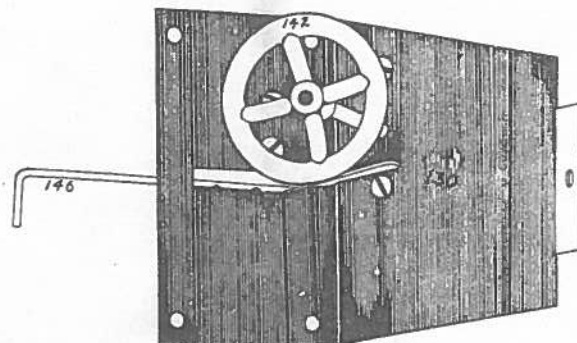
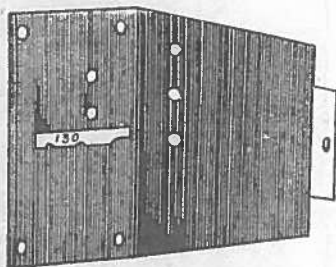
Lock Nut
on Bolt 39

FOOT BOARD—Top View

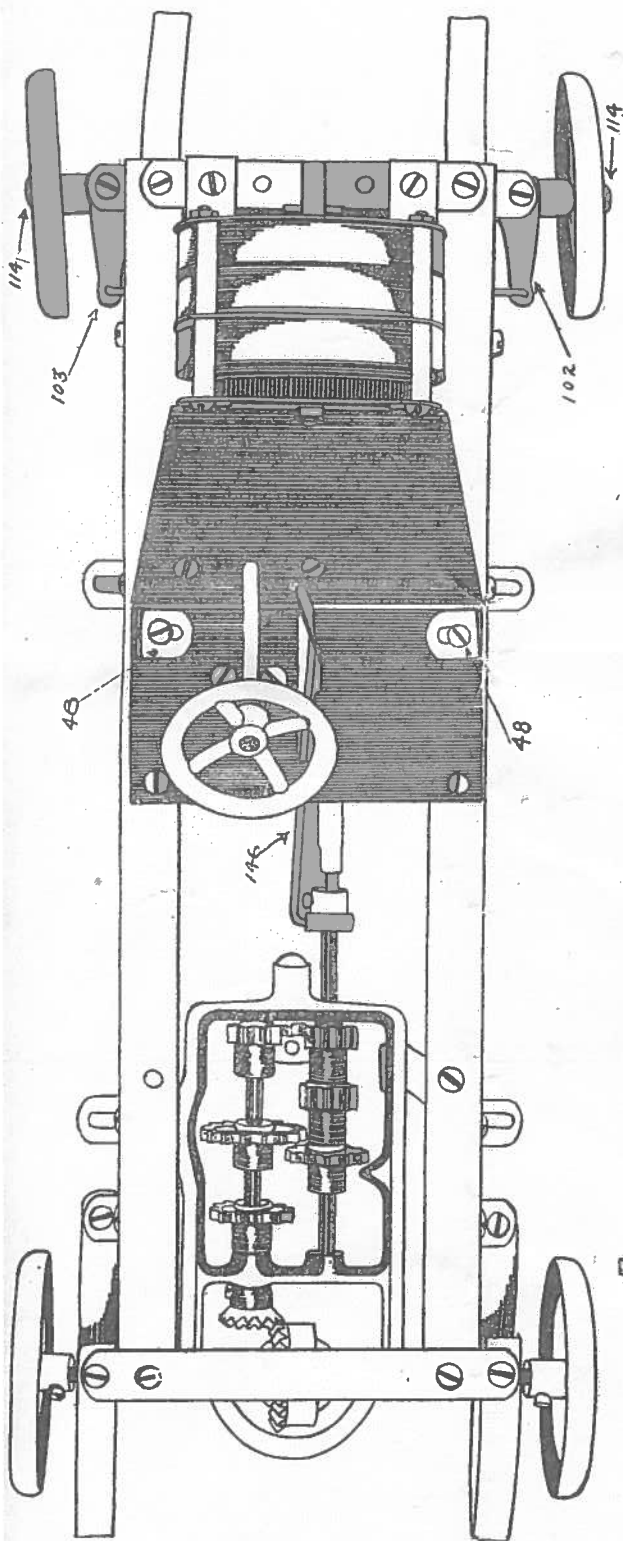
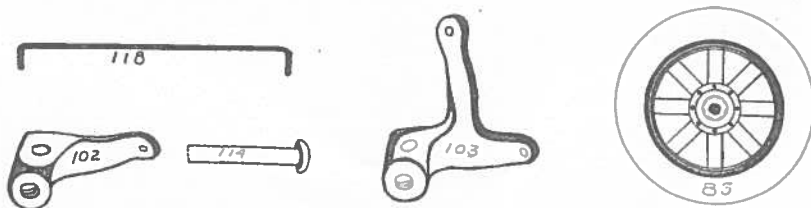

ILLUSTRATION C



Assembly of No. 12 Chassis

REFER TO ILLUSTRATION C

PLACE assembled footboard on frame in position shown. Bolt rear corners of footboard to frame side members. Place brackets 48 with slotted side next to footboard and bolt in place.

Place right steering knuckle 102 in position shown and fasten in axle with two short bolts, one above and one below. Do not screw these bolts all the way in at this time. Insert end of steering cross rod 118 in small hole in the end of right knuckle 102, and other end in corresponding hole in left knuckle 103. The illustration shows only the ends of steering cross rod. Now bolt left steering knuckle 103 to front axle but do not tighten bolts.

Assemble two front wheels on car by placing auto wheel 83 on front wheel spindles 114 and inserting end of spindle 114 in hole in steering knuckles 102 and 103; then tighten bolts which hold knuckles in place. Be sure that wheels turn freely on spindles.

Place triple unit motor 154 in place with brackets BB bolted to front cross member as shown. Always keep motor well oiled.

Place transmission in chassis, (pronounced "shassy,") by putting one axle inside one of the rear springs but not through the bearing; then the opposite axle can be manipulated through its bearing. Shove entire transmission against this bearing and other axle can be forced through its bearing.

Insert rod 146 that is on Control Lever, into the holes in the swiveled collar on the Transmission Shaft. Turn the collar to bring the holes on top of shaft before inserting rod.

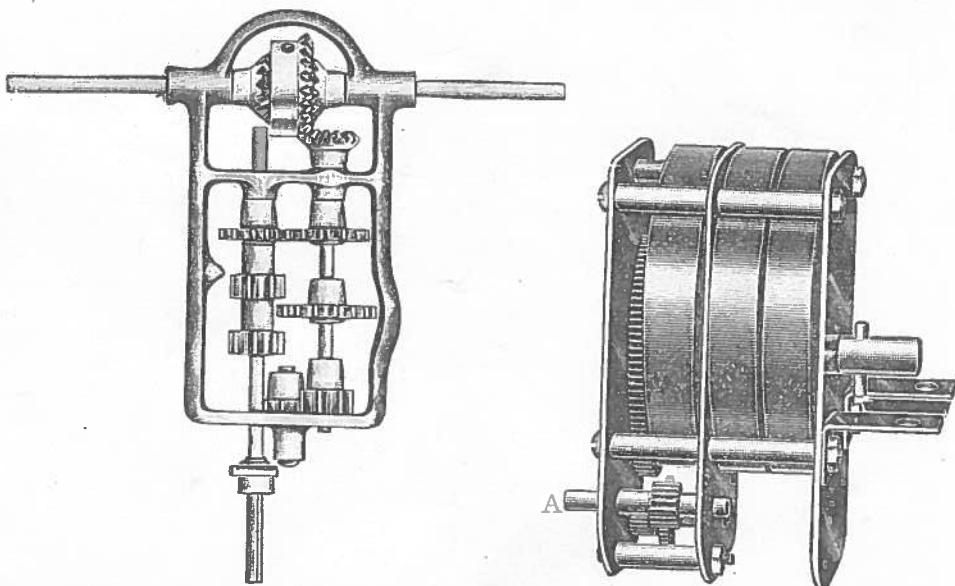

TRANSMISSION AND DIFFERENTIAL

TRIPLE MOTOR No. 154

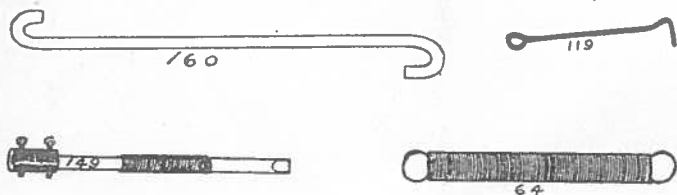

Assembly of No. 12 Chassis (Continued)

REFER TO ILLUSTRATION D

FASTEN rear wheel on axles by set-screws in hubs of wheels. Remove set-screws from front wheels, they are not used.

Insert hooked end of steering gear reach rod 119 in remaining hole in left steering knuckle. Slip looped end of same rod over end of crank on steering gear case. Loop end of coil spring over same crank and fasten in place by thrusting cotter through small hole in crank and spreading the "split" end of cotter key. Hook one end of steering gear spring rod 150 into hole in left frame side member, as shown, and loop end of coil spring over other end of rod.

Connect the Motor with the transmission by slipping flattened end of propeller shaft 149 over end of flattened shaft of transmission. Then other end of propeller shaft 149 can be put on motor shaft marked A in picture of motor. Turn propeller shaft until holes through end of it meet holes through motor shaft, put cotter key through holes and spread split ends of cotter key.

Before the car is tested, go over it carefully to make sure that you have constructed it according to instructions.

See that motor has been well oiled and bolts well tightened.

Run Car back and forth with hand to see that nothing binds.

When you are sure that the Car is constructed right, set control lever so that projection located at right of transmission frame (Illustration D) engages teeth of one gear and prevents shaft from turning. Wind motor with crank 156, giving crank nine turns.

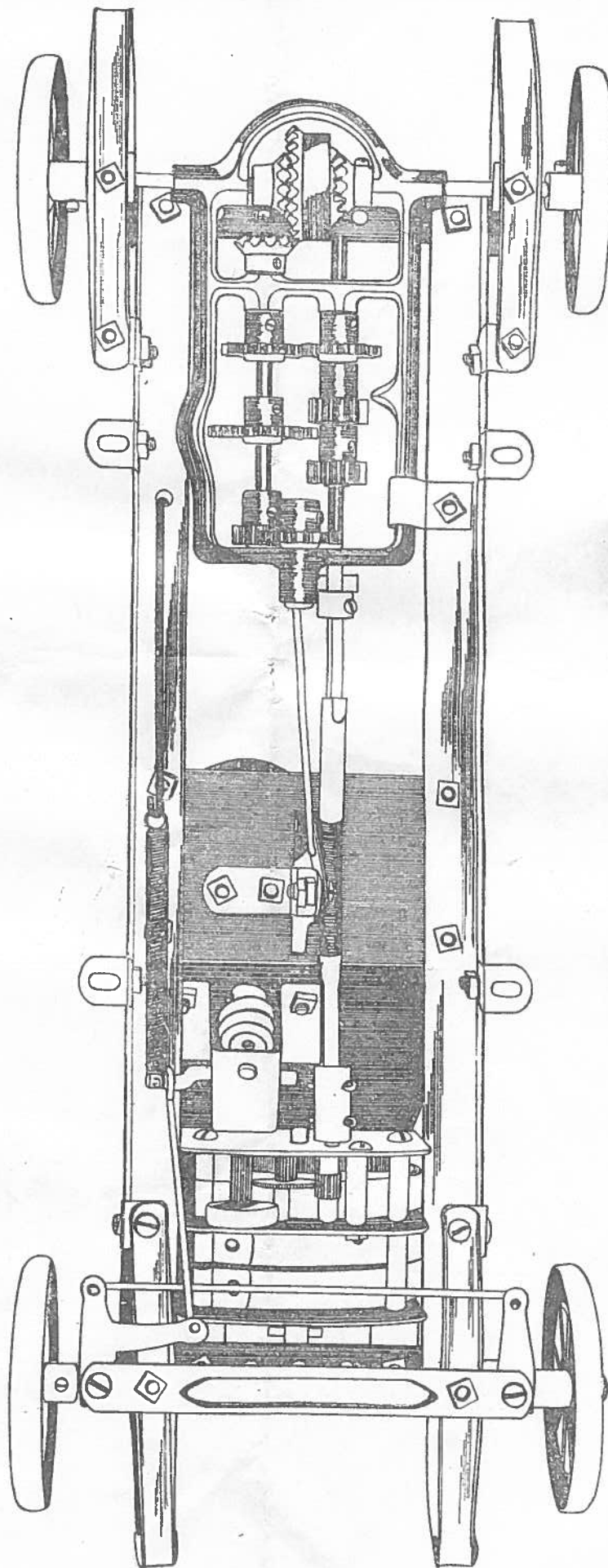
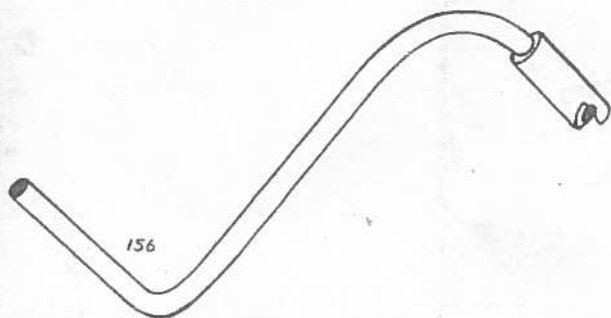

ILLUSTRATION D

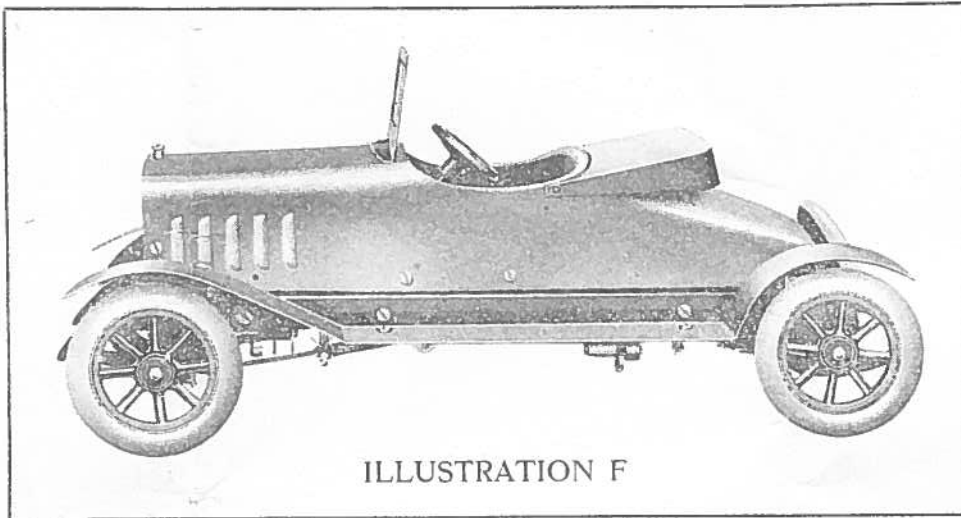
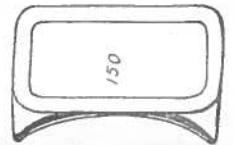

ILLUSTRATION F

Completion of Automobile
REFER TO ILLUSTRATION F



ASSSEMBLE seat 145 in body 144 and bolt together.

Assemble "fifth wheel" on body by thrusting long bolt 39 through hole in body from the underside. Set wheel on bolt and secure in place by tightening set-screw in hub. Set wheel tight against body.

Assemble body on chassis by inserting bolts through remaining holes in body and then through brackets on footboard. Spring body as much as may be necessary to insert bolts.

Bolt windshield to body.

Fasten steering wheel 142 on steering post by means of set-screw in hub.

Bolt right fender 151 and left fender 152, (picture at side of page shows right fender 151), to brackets already fastened to frame side members,—short curves over rear wheels.

Set finished Auto on floor or table and see if all wheels touch; if not, grasp Auto by ends and twist to true up frame.

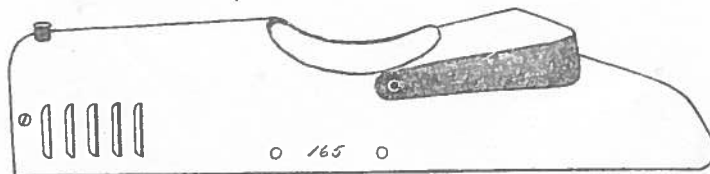
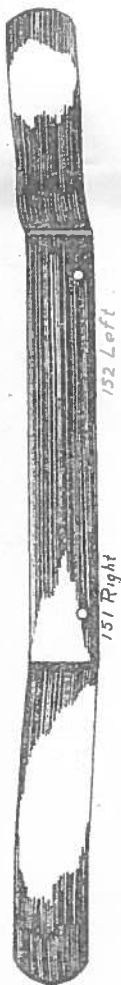
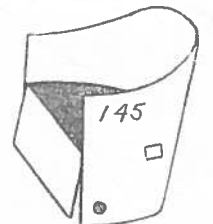

Operation of Automobile No. 12.

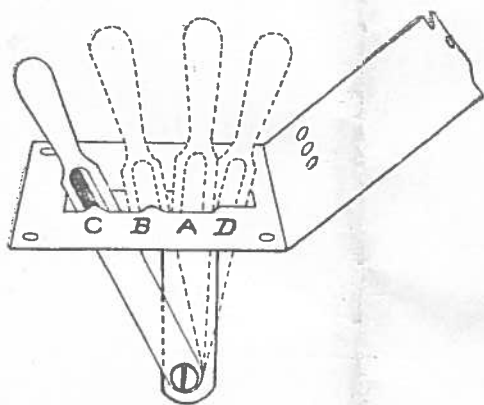

THE shifting mechanism is clearly shown by the drawing on this page.

When Control Lever is set in position "A" the Gears are in "Neutral".

The Control Lever **must always be set at "Neutral"** before cranking car.

When Control Lever is set in position "B" gears are in "Low" and position "C" is "High".

To "Reverse" shift Control Lever forward to position "D".

To shift gears move car slightly backward and forward with one hand and shift control lever with the other hand.

Never shift gears except when car is moving.

In cranking the car place control lever in position "A" (Neutral). Place car on edge of table, hold the front end down firmly and crank nine turns.

GENERAL SUGGESTIONS.

Keep motor and all working parts well oiled at all times, with good grade oil; sewing machine oil will serve the purpose.

All big Automobiles have to be cleaned so they will look bright and new. Structo cars, after continued use, may be made to look just as bright as new.

Remove body and fenders from chassis when washing so that water will not get into machinery. Slightly dampen a soft cloth with water and Ivory soap and rub over parts to be cleaned. Rinse with clear water and dry with another soft cloth. Now rub parts with a cloth very light, dampened with oil. The parts will then be bright and glossy like new.

If you have any difficulty in assembling your car, write direct to the Structo Company, and we will assist you with any suggestions that may seem necessary.

Structo Manufacturing Company

FREEMONT, ILLINOIS