

# MECCANO

## STANDARD MECHANISMS

PRICE



50 CENTS

IMPORTANT MECHANICAL MOVEMENTS CONSTRUCTED & DEMONSTRATED WITH MECCANO.  
Gears, Clutches, Drive-changes, Belts, Pulleys, Levers, Brakes, Screw Gearing etc.

**MECCANO COMPANY**  
INCORPORATED  
ELIZABETH, NEW JERSEY

# Model-Building With Meccano

Real Engineering

in Miniature

MECCANO OUTFITS contain accurately-made and highly-finished engineering parts with which any known mechanical movement may be reproduced in model form.

Meccano owes its world-wide renown to the fact that every one of the 200 parts contained in the system is designed on correct principles. Every piece is standardised and interchangeable, so that the use of any part is not confined to one purpose only—the same part may be used in a variety of ingenious combinations.

When you build models with Meccano you use real engineering parts in miniature, for they act in a precisely similar manner to the corresponding elements in actual practice. This means that with Meccano you can accomplish more than with any other system of model construction. Other systems attempt to attain the same object by

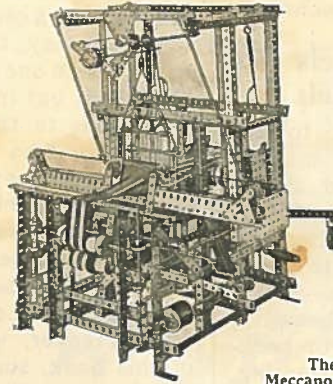

The Meccano Loom

different methods, and avail themselves of constructive elements that are not based on correct engineering principles. It is important to realise this, for if you commence with badly-designed parts you can only build a very limited number of models. Even these will necessarily be constructed incorrectly and will give you faulty ideas of the laws of engineering.

For these reasons, Meccano becomes something more than a toy—it is an educational medium of very real value.

Professors of Engineering, bridge-building experts, draughtsmen, and others who are in a position to judge, have from time to time pronounced on the Meccano system. All have declared it to be conceived on sound lines and based on true engineering principles.

We have numerous records in our files of great

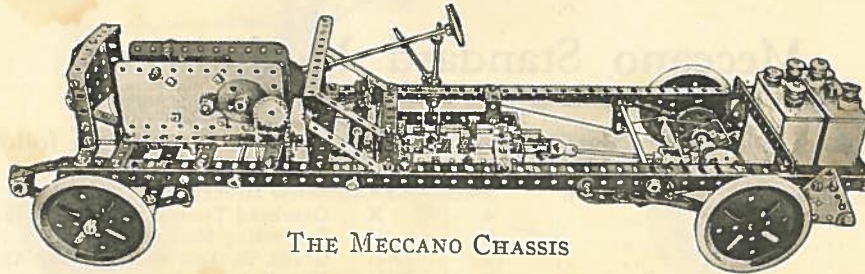

THE MECCANO CHASSIS

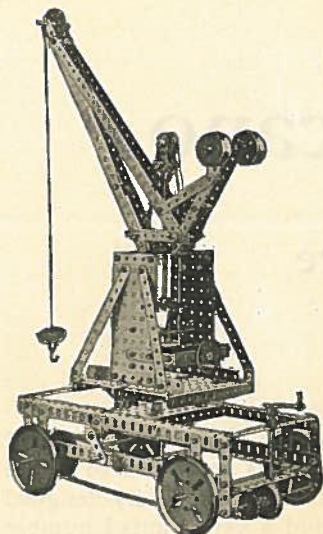

HYDRAULIC CRANE

engineering firms who employ Meccano every day for designing movements or engineering structures they are about to build. Famous inventors use it for experimenting and for working out ideas, while in schools and colleges it is used to demonstrate all branches of mechanics.

### Meccano Models are Real Models

There is no limit to the number of models that may be built with Meccano, and all are real working structures.

The Meccano clock is a real clock—it keeps accurate time. The Meccano Loom is a real loom, for it weaves beautiful material for hat-bands or neckties.

The Meccano Motor Chassis, with worm-and-wheel steering, gear-box and differential, so closely resembles a real motor-car that it is used for teaching students at numerous Schools of Motoring.

It is the same with all other Meccano models—they are all accurate reproductions of the real thing and they all work because they are based on correct engineering principles.

## The Meccano Standard Mechanisms

No Meccano boy is content to build only the models illustrated in the Meccano Manuals, for every boy who thinks is keen on inventing and likes to build models from his own ideas. With this in mind, and to assist boys to embody correct engineering practices in their new models, we have collected and classified a number of Meccano movements that have to a certain extent become standardised. That is to say, these movements may be applied to more than one model—in most cases without any alteration, but in some few cases with only slight alterations to the standard movement.

Those who invent with Meccano will find these movements, which we now publish as "Standard Mechanisms," of great assistance in helping to perfect their models. The various devices have been arranged so that immediate reference may be made to any particular motion that it is desired to incorporate in a model.

Moreover, we believe that certain sections of this book, such as those dealing with Pulleys and Levers, will serve as an interesting introduction to elementary Mechanics. In any event, some knowledge of the principles involved in these details will well repay the study of any boy interested in engineering.

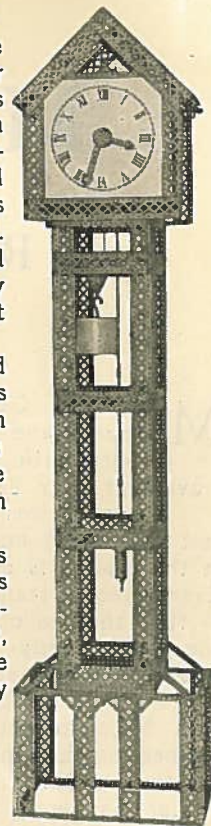

THE MECCANO CLOCK

## Meccano Standard Mechanisms

### CONTENTS

For easy reference purposes, the various mechanisms have been grouped under the following SECTIONS:—

|      |   |      |       |   |               |    |
|------|---|------|-------|---|---------------|----|
| I.   | Gear Ratios : Methods of Speed Reduction and Acceleration | Page | 3     | VIII.   | Steering Gear | 26 |
| II.  | Belt and Rope Mechanism                                   | 4    | IX.   | Screw Mechanism                                 | 28            |    |
| III. | Pulleys and Pulley Blocks                                 | 5    | X.    | Overhead Trolleys and Trucks for Gantries, etc. | 31            |    |
| IV.  | Levers  | 11   | XI.   | Traversing Mechanism                            | 33            |    |
| V.   | Clutches, Reversing and Drive Changing Mechanism          | 16   | XII.  | Grabs, Buckets and Dredging Apparatus           | 35            |    |
| VI.  | Brakes and Retarding Appliances                           | 21   | XIII. | Miscellaneous Appliances                        | 36            |    |
| VII. | Roller and Ball Bearings, etc.                            | 23   |       | Experiments in Applied Mechanics                | 44            |    |
|      |   |      |       | Index   | 47            |    |

# Model-Building With Meccano

## Real Engineering

**M**ECCHANO OUTFITS contain accurately-made and highly-finished engineering parts with which any known mechanical movement may be reproduced in model form.

Meccano owes its world-wide renown to the fact that every part contained in the system is designed on correct engineering principles. Every piece is standardised and interchangeable, so that the use of any part is not confined to one purpose only—the same part may be used in a variety of ingenious combinations.

When you build models with Meccano you use real engineering parts in miniature, for they act in a precisely similar manner to the corresponding elements in actual practice. This means that with Meccano you can accomplish more than with any other system of model construction. Other systems attempt to attain the same object by

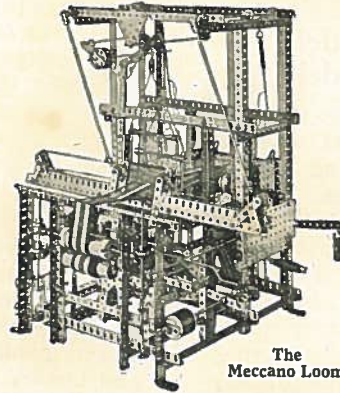

The Meccano Loom

## in Miniature

different methods, and avail themselves of constructive elements that are not based on correct engineering principles. It is important to realise this, for if you commence with badly-designed parts you can only build a very limited number of models. Even these will necessarily be constructed incorrectly and will give you faulty ideas of the laws of engineering.

For these reasons, Meccano becomes something more than a toy—it is an educational medium of very real value.

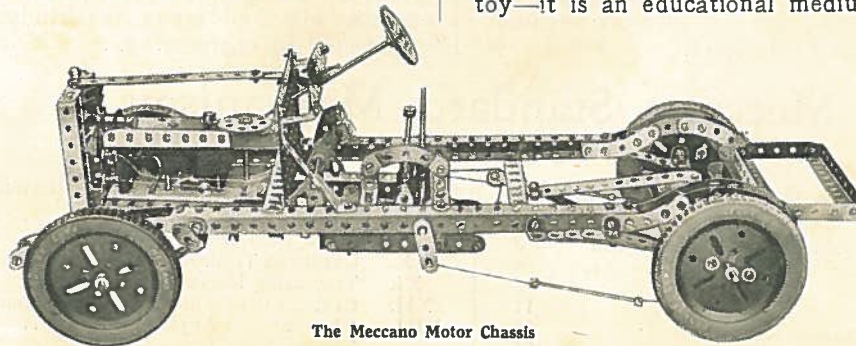

The Meccano Motor Chassis

Professors of Engineering, bridge-building experts, draughtsmen, and others who are in a position to judge, have from time to time pronounced on the Meccano system. All have declared it to be conceived on sound lines and based on true engineering principles.

We have numerous records in our files of great

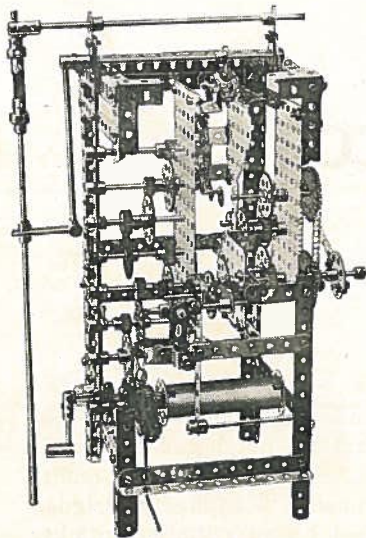

Clock Mechanism

engineering firms who employ Meccano every day for designing movements or engineering structures they are about to build. Famous inventors use it for experimenting and for working out ideas, while in schools and colleges it is used to demonstrate all branches of mechanics.

### Meccano Models are Real Models

There is no limit to the number of models that may be built with Meccano, and all are real working structures.

The Meccano clock is a real clock—it keeps accurate time. The Meccano Loom is a real loom, for it weaves beautiful material for hat-bands or neckties.

The Meccano Motor Chassis, with "Ackermann" steering gear, gear-box and differential, so closely resembles a real motor-car, that it is used for teaching students at numerous Schools of Motoring.

It is the same with all other Meccano models—they are all accurate reproductions of the real thing and they all work because they are based on correct engineering principles.

### The Meccano Standard Mechanisms

No Meccano boy is content to build only the models illustrated in the Meccano Manuals, for every boy who thinks is keen on inventing and likes to build models from his own ideas. With this in mind, and to assist boys to embody correct engineering practices in their new models, we have collected and classified a number of Meccano movements that have to a certain extent become standardised. That is to say, these movements may be applied to more than one model—in most cases without any alteration, but in some few instances with only slight alterations to the standard movement.

Those who invent with Meccano will find these movements, which we now publish as "Standard Mechanisms," of great assistance in helping to perfect their models. The various devices have been arranged so that immediate reference may be made to any particular motion that it is desired to incorporate in a model.

Moreover, we believe that certain sections of this book, such as those dealing with Pulleys and Levers, will serve as an interesting introduction to elementary Mechanics. In any event, some knowledge of the principles involved in these details will well repay the study of any boy interested in engineering.

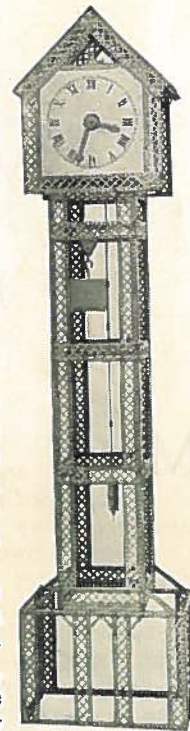

The Meccano Clock

## Meccano Standard Mechanisms

### CONTENTS

For easy reference purposes, the various mechanisms have been grouped under the following SECTIONS:—

|   | Page |  | Page |
|---|------|--|------|
| I. Gear Ratios: Methods of Speed Reduction and Acceleration | 3    | VIII. Steering Gear .. .. .                                | 26   |
| II. Belt and Rope Mechanism .. .. .                         | 4    | IX. Screw Mechanism .. .. .                                | 28   |
| III. Pulleys and Pulley Blocks .. .. .                      | 5    | X. Overhead Trolleys and Trucks for Gantries, etc. .. .. . | 31   |
| IV. Levers .. .. .  | 11   | XI. Traversing Mechanism .. .. .                           | 33   |
| V. Clutches, Reversing and Drive-Changing Mechanism .. .. . | 16   | XII. Grabs, Buckets and Dredging Apparatus .. .. .         | 35   |
| VI. Brakes and Retarding Appliances .. .. .                 | 21   | XIII. Miscellaneous Appliances .. .. .                     | 36   |
| VII. Roller and Ball Bearings, etc. .. .. .                 | 23   | The Inclined Plane .. .. .                                 | 43   |
|   |      | Index .. .. .  | 47   |

# Section I. GEAR RATIOS.

## Methods of Speed Reduction and Acceleration

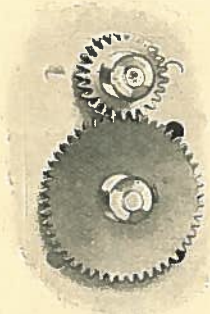

S.M. 1— $\frac{1}{4}$ " Pinion and 50-teeth Gear Wheel.  
Ratio, 2 : 1.

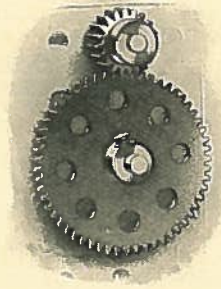

S.M. 2— $\frac{1}{2}$ " Pinion and 57-teeth Gear Wheel.  
Ratio, 3 : 1.



S.M. 7—Chain Gear  
 $\frac{3}{4}$ " and  $3$ " diam. Sprocket Wheels.  
Ratio, 4 : 1.  
1" and 2" diam. Sprocket Wheels.  
Ratio, 2 : 1.  
 $\frac{3}{4}$ " and  $1\frac{1}{2}$ " diam. Sprocket Wheels.  
Ratio, 2 : 1. etc., etc.  
Ratios of 1 : 1 may be obtained by gearing any two Sprocket Wheels of like diameter

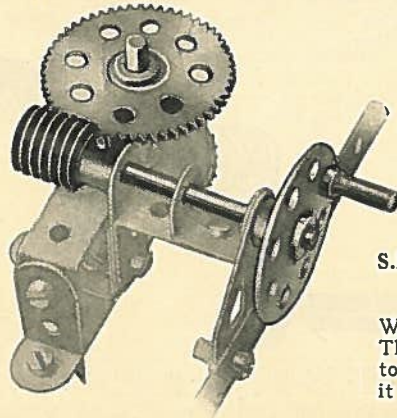

S.M. 5—Worm Gearing. Worm Wheel and 57-teeth Gear Wheel.  
Ratio, 57 : 1.  
Worm Wheel and  $\frac{1}{2}$ " Pinion. Ratio, 19 : 1.  
The number of revolutions of any Gear Wheel to one revolution of the Worm Wheel by which it is driven may be assumed to correspond with the number of its teeth.

For Shafts at Right Angles

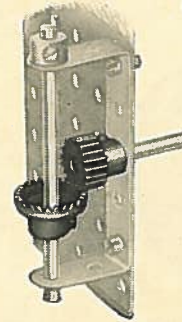

S.M. 3— $\frac{1}{2}$ " Pinion and  $\frac{3}{4}$ " Contrate Wheel. Ratio, Approx.  $1\frac{1}{2}$  : 1.

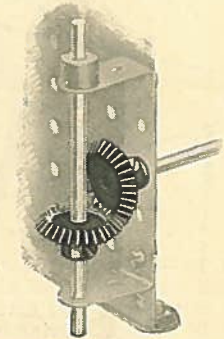

S.M. 4—Bevel Gears  
Ratio, 1 : 1.

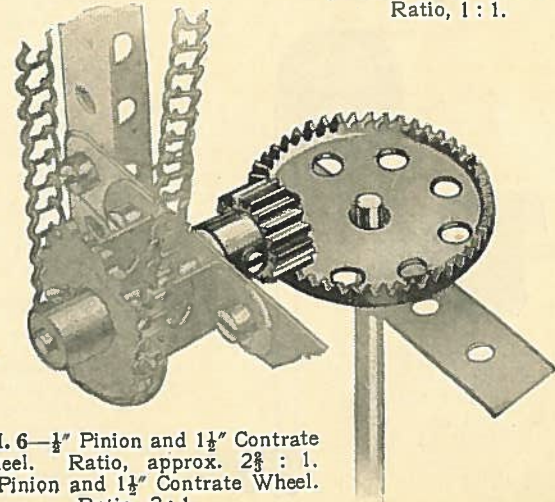

S.M. 6— $\frac{1}{2}$ " Pinion and  $1\frac{1}{2}$ " Contrate Wheel. Ratio, approx.  $2\frac{3}{4}$  : 1.  
 $\frac{3}{4}$ " Pinion and  $1\frac{1}{2}$ " Contrate Wheel. Ratio, 2 : 1.

## Section II. BELT AND ROPE MECHANISM

In Meccano models, cords usually take the place of belts for this method of power transmission. Miniature belting may be made, however, from strips of canvas, indiarubber, etc., in which case Flanged Wheels should be used, either singly or in pairs (as in S.M.18), instead of grooved pulleys. The Meccano Spring Cord also forms an excellent means of connection between pulleys.

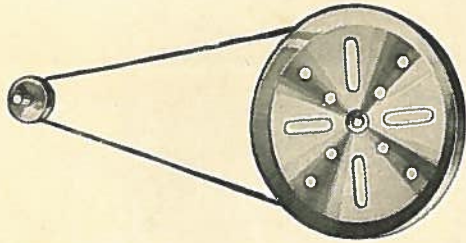

**S.M. 15**—Open Belt Gear. A wide range of speeds may be procured with Meccano Pulleys and belt gear. This detail illustrates the  $\frac{1}{2}$ " and 3" Pulleys, giving great difference in speed between the two shafts.

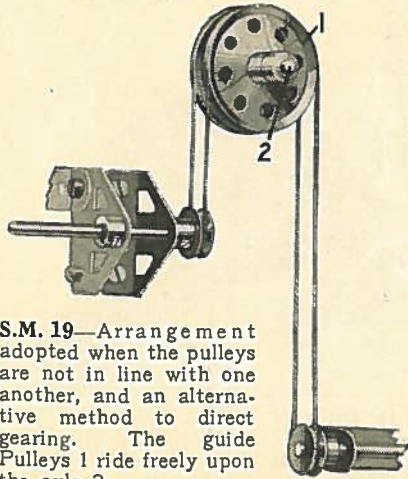

**S.M. 19**—Arrangement adopted when the pulleys are not in line with one another, and an alternative method to direct gearing. The guide Pulleys 1 ride freely upon the axle 2.

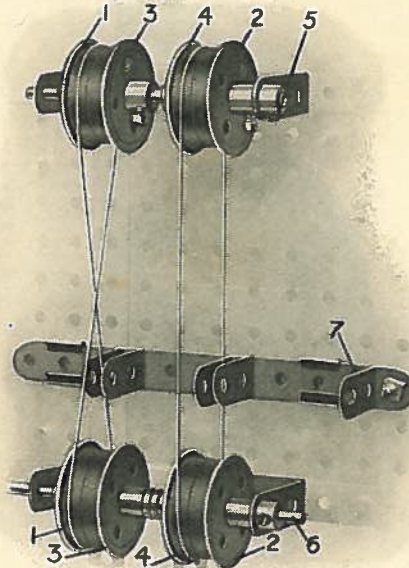

**S.M. 18**—Belt Reversing Gear. Two pairs of Flanged Wheels, 1 and 2, are fixed, and two pairs, 3 and 4, are loose on a driving shaft 5 and a driven shaft 6. The wheels 1 are connected by a crossed belt, thereby reversing the motion of the driven shaft 6 (as in S.M.17), while the wheels 4 are connected by an open belt. The operation of a lever 7 brings one of the belts on to a pair of fixed pulleys, at the same time throwing the other on to a loose shaft pair, and vice versa, thereby reversing the action of the driven shaft 6.

**S.M. 18a**—Belt Clutch. In the above illustration, the pulleys 4 and 2 also demonstrate the principle of a belt clutch. The driven shaft 6 may be thrown into gear with the shaft 5 by moving the belt on to the fixed pair of wheels 2, and by reversing the operation it may be thrown out of gear again without stopping the driving shaft 5.

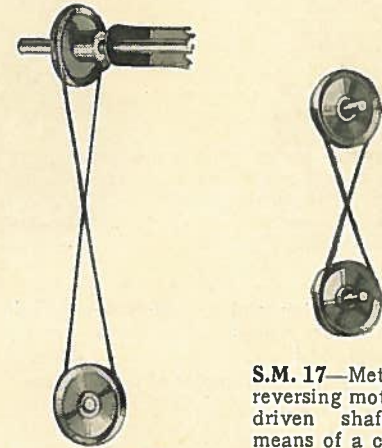

**S.M. 16**—Driving two shafts at right-angles to one another.

**S.M. 17**—Method of reversing motion of driven shaft by means of a crossed belt.

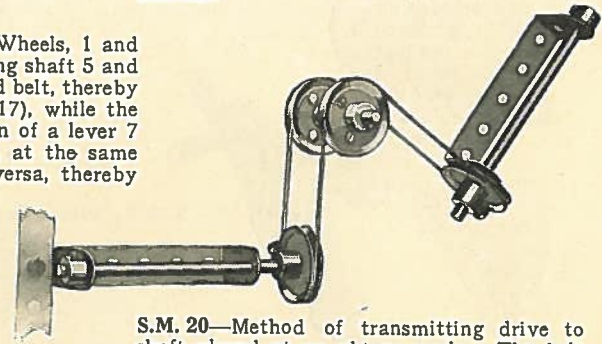

**S.M. 20**—Method of transmitting drive to shaft placed at an obtuse angle. The belt is led round the 1" loose guide Pulleys.

## Section III. PULLEYS AND PULLEY BLOCKS

**P**ULLEYS play such an important part in engineering that a knowledge of the principles upon which they work is essential to every engineer, whether professional or amateur.

Pulleys are a development of the lever, and when scientifically employed make possible a great saving of labour and energy. A fixed pulley cannot be described as a mechanical power, for it simply changes the direction of a force without increasing it—in fact, a small amount of energy is lost in its use owing to friction. The combination of a rope with several pulleys, however, produces a mechanical power, and with the help of a few experiments we shall endeavour to explain as simply as possible some of the interesting results so obtained.

A man carrying a sack of cement to the top of a building has to carry his own weight in addition to that of the sack. If he attaches a rope to his load and passes the rope over a pulley fixed at the top of the building, he is then able to raise the load by hauling on the other end of the rope while he remains on the ground. This is an example of the pulley used as a convenient method of changing the direction of a force, for it changes the man's downward pull to an upward force by which he is able to raise the sack of cement. It must be remembered that although the man has eliminated his own weight, he has not diminished his load. On the other hand he has increased it, for the energy he now exerts must not only equal the weight of the load but must also overcome a certain amount of friction.

### The Meaning of "Energy"

The amount of work, or "energy," of which a machine is capable is measured by "foot-lbs." The unit of this is based on the amount of energy necessary to raise a 1 lb. weight through a height of 1 ft. For example, suppose a weight of 2 lbs. has to be raised through a height of 1 ft.; the energy required would be exactly equal to that necessary to raise a weight of 1 lb. through a height of 2 ft.—namely, 2 foot-lbs.

If 10 lbs. be lifted 100 ft., 10 foot-lbs. are required for the first foot, the same for the second, third, and so on up to 100 ft., making a total of 1,000 foot-lbs. of energy.

Supposing a man, by hauling on a rope, lifts 1 cwt. to a height of 20 ft. The energy he expends should be sufficient to raise a load of one ton through a height of 1 ft., but it is impossible, of course, for a man to move a direct load of one ton, however short the height through which it is to be moved, although he can create sufficient energy (2,240 foot-lbs., or 1 foot-ton) when moving a load of 1 cwt. through a height of 20 ft. With the aid of a series of pulleys, however, he is able to arrange a contrivance with which he may lift one

ton through 1 ft. by the same means; i.e. by moving a smaller weight, or exerting a smaller pull, through a greater height.

### Friction in Pulleys

Friction plays an important part in calculating the advantages of pulleys, although in the majority of Meccano models its effect is naturally very small. In every pulley there is a slight loss of power from the necessity of bending the rope, and in actual practice, where heavy ropes are used, this loss becomes of great importance. It is for this reason that pulleys are usually made as large as possible, for the bending of a rope around the circumference of a large pulley creates less friction than when used with a smaller pulley. Small pulleys also cause damage to the rope by excessive bending.

### Example 1

A simple fixed pulley is shown in Fig. 1.

If we attach a hook to the rope at the point where it is tied to the base, and suspend from this hook a weight equal to that already shown, we find that the original weight remains suspended in mid-air, in spite of the law of gravitation by which the highest weight should fall, thereby raising the lower weight.

Because this is the case, we know that there must be some force that is retaining the suspended weight in position. This force is friction, created by the bending of the cord and from the contact of the pulley on its bearings. If a 50-gramme weight is attached to each hook, we find that the addition of five Washers is required to the uppermost hook to cause the weight to fall, so raising the other hook supporting the lower weight. Thus the amount of friction present in our model is equal to the weight of five Washers.

### Example 2

In Fig. 2 we have a moveable pulley B in addition to our fixed pulley A. The rope is fastened to the cross beam, passed (or "rove") through the moveable pulley B, and over the fixed pulley A.

With this arrangement it will be found that a power load of, say, 11 lbs. attached to the free or "running" end *a* of the rope will raise a weight of 20 lbs. suspended from the moveable pulley B. Here, then, the moveable pulley B is employed as a mechanical power and gives an advantage of nearly double the available force. To this mechanical advantage the fixed

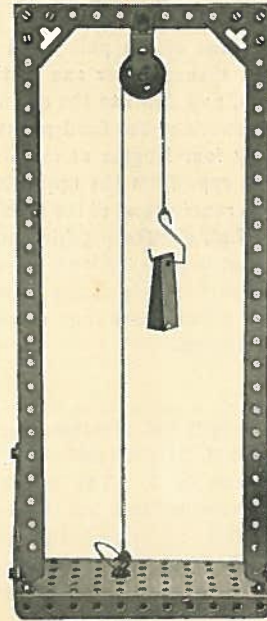

Fig. 1  
Single Fixed Pulley



## Section III. Pulleys and Pulley Blocks—(continued)

pulley A does not contribute, but only changes the direction of the force, converting a downward pull on the rope at *a* to an upward force at *b*.

The explanation of the increased power, or mechanical advantage, obtained is as follows. In our model we find that to raise the load 1 in. the power must descend 2 in.—for it is clear that if B is to rise 1 in. the lengths of rope *c* and *b* must each be shortened by 1 inch—therefore *a* must be lengthened by 2 in. To raise 20 lbs. through 1 ft. requires 20 foot-lbs. But the power load of 11 lbs. descending through twice that distance—2 ft.—yields 22 foot-lbs. This is 2 foot-lbs. more than is actually necessary; hence it may be stated that friction has absorbed 2 foot-lbs. of the energy exerted.

From this we learn that a moveable pulley enables a force to move through a greater distance than that moved by the load it lifts. We also know that the energy exerted by a force is increased proportionally to the distance through which it moves. Therefore by using a single moveable pulley we may almost halve the force that would be necessary without it, for it enables us to move the force through a distance twice as great. It should be noted here that in all the mechanical powers, the force is increased always at the expense of speed, since it must move through a greater distance than the load it lifts.

### Example 3

The principle in Fig. 3 is the same as in Example 2, but two further pulleys have been added. The rope is rove through one of the pulleys, or "sheaves" as they are termed, situated in the fixed pulley block, thence under one of the sheaves in the lower moveable block, over the second fixed sheave, and down to the second moveable sheave. From here it is lead up and secured to the framework of the fixed pulley block.

The load is thus supported by four lengths of rope, and to raise the load through one inch, each of the four parts of the rope from the upper block to the lower block must be shortened one inch. Therefore, the running end of the rope must be lengthened by four inches, from which it may be calculated that, eliminating friction, one quarter of the load attached to the running end would be sufficient to raise the load, for, as we have already seen, the energy exerted by a force is increased proportionately to the distance through which it travels. In actual practice it will be found that a little more than a quarter of the load is required to raise it, the surplus being absorbed by friction.

### Example 4

A popular arrangement of pulleys is well illustrated in the Meccano Model No. 709, Stiff-Leg Derrick Crane. As shown in S.M. 31 the tackle here consists of two pulley blocks, one fixed and one moveable, as in Example 3. The upper block contains two sheaves or pulley wheels, while the lower or moveable block has three sheaves. The end of the cord that passes over the large pulley in the jib of the crane is the running-end.

The model shown in Fig. 4 makes the relative arrangement of the sheaves and cords easier to understand. As will be seen, instead of all the sheaves in one block being on the same axle they are separated in this model one from another. The action of the pulleys in Fig. 4 is similar to that in the Stiff-Leg Derrick.

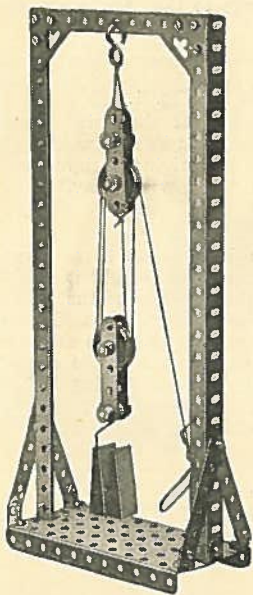

Fig. 2  
The Single  
Moveable Pulley

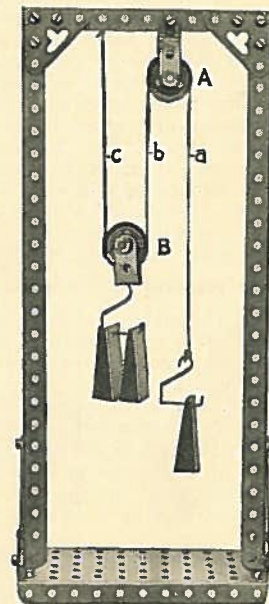

Fig. 3  
The Two-Sheave  
Pulley-Block

## Section III. Pulleys and Pulley Blocks—(continued)

In this case we have six lengths of cord supporting the moveable pulley block, so by a similar calculation to that made in Example 3, it will be seen that we obtain a mechanical advantage of six—that is, a force equal to one sixth of the load will be sufficient to raise it (ignoring friction).

### Example 5

In Fig. 5 separate cords are substituted for the previous continuous single cord. One end of the outermost cord is attached to a Strip D and the cord then passes over the pulley A, which is bolted to the upper framework. The other end of this cord is fixed to the block B. The centre cord is also fastened to D and then passes over the pulley B to be secured to the block C. The remaining cord passes over the pulley C, and serves as the running or pulling-end of the tackle. The load E is suspended from the Strip D, and the power F is attached to the running-end of the cord C.

With this ingenious arrangement we obtain a mechanical advantage of seven; that is, it enables a load of, say, 70 lbs. to be lifted by an applied force of only 10 lbs. (ignoring friction).

The explanation is not quite so obvious, perhaps, as in our previous examples. If D is raised 1 in. the block B, suspended from the first cord that passes over A, must fall 1 in. Since the pulley B descends 1 in. that part of the second cord between B and C must be lengthened by 2 in. (We learned in Example 2 that to raise a moveable pulley 1 in., 2 in. of cord must be drawn up—therefore to drop a moveable pulley 1 in., 2 in. of cord must be let down). We must remember that D has risen 1 in. so that the second cord has been lengthened by a further inch between B and C. Therefore the pulley C has dropped 3 in. altogether. From this, again working on the theory of the moveable pulley, we find that the running end of the third cord, which passes over the pulley C, must descend through 6 in. Finally, by adding to the running end the additional length of 1 in. derived from the movement of D, we arrive at the total movement of the power load F, namely, 7 in.

Therefore if the power load is 10 lbs., it exerts 70 foot-lbs. energy for every foot the load is raised.

It should be mentioned that in the Meccano model it is first necessary to balance the weight of the pulley blocks B, C. This may be done by suspending a weight of approximately 75 grammes from the Strip at D. Then having attached a load of, say, 175 grammes, at E we find that 25 grammes on the power hook F is sufficient to balance it. By the addition of about eight Washers the load is raised; therefore the loss by friction is equal to the weight of the Washers.

This arrangement of cords and pulleys, though using a smaller number of sheaves than the continuous cord system, is seldom employed by engineers for the reason that the continuous cord is more convenient to fix and use.

### Example 6

Our final example deals with a very ingenious contrivance, known as Weston's differential pulley block. This apparatus consists of three parts—an upper fixed pulley block, a moveable pulley and an endless chain (Fig. 6). In our Meccano model, the load C may be raised or lowered by a slight pull on the chain at A or B.

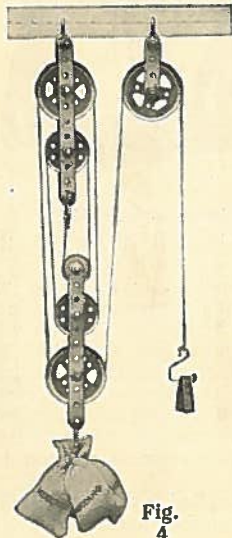
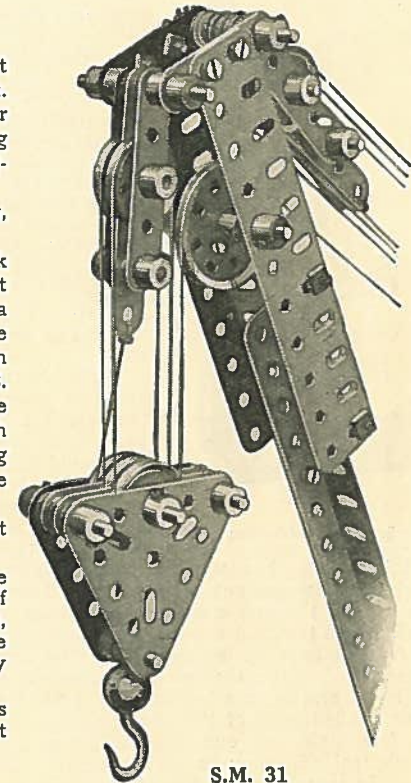

Fig.  
4



S.M. 31  
Arrangement of Pulleys  
in Stiff-Leg Derrick  
(Model No. 709)

## Section III. Pulleys and Pulley Blocks—(continued)

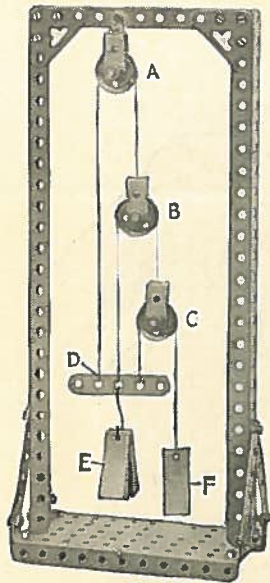

Fig. 5

Separate Cord System

have taken place, however, by raising the moveable pulley H through half that amount, that is,  $\frac{1}{2}$  in. Therefore the power at A has moved through a distance 18 times greater than that through which the load moves, for in order to rotate the axle F once, A must have pulled out  $4\frac{1}{2}$  in. (the circumference of D). This means that the theoretical mechanical advantage in our model is 18, and by it a load of, say, 1,800 lbs. could be raised with an applied force of 100 lbs.

A few trials with our Meccano model, however, will show that the real efficiency is not so great. Although in actual practice the contrivance would enable a man to lift a load of over a quarter of a ton, more than 50 per cent. of the power is lost in friction. This leads to a very interesting result, for the load when hoisted remains suspended, and it will not descend unless we actually haul on the chain at B.

If a weight of 450 grammes is placed on the load hook, we

The principle on which this pulley block is based will be understood from the diagram shown in Fig. 7. Two Gear Wheels, D (57 teeth) and E (50 teeth), are employed as the sheaves in the fixed pulley block, in order that their teeth may prevent the chain from slipping. They are both secured to the axle F, and must therefore turn together at similar speeds. The chain passes from the hand at A over the larger sheave D, then downwards at G, and under the moveable pulley H, which supports the load. It passes up again at K, over the smaller sheave E, and then back again by B to the hand at A.

When A is pulled downwards, the sheaves D and E must both rotate in the direction indicated by an arrow in the diagram. The larger sheave D is therefore winding up the chain at G while E is lowering at K.

The effective circumference of D is  $4\frac{1}{2}$  in. and that of E is 4 in. In one revolution of the axle F, D must draw up  $4\frac{1}{2}$  in. of chain; but in the same time E has lowered 4 in.; hence the length of chain between the two must have been shortened by  $\frac{1}{2}$  in. (the difference between  $4\frac{1}{2}$  in. and 4 in.) This can only

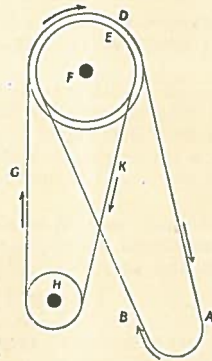

Fig. 7

know that, theoretically, 25 grammes attached by means of a hook to the chain at A should raise it. Actually, it will be found that no less than 70 grammes are necessary (this weight may be arrived at by using one 50 gramme weight and four 3 in. Strips, for the latter equal approximately 20 grammes). Friction therefore absorbs 45 grammes, or about 64 per cent. of the power. Since we must use 70 grammes to raise 450 grammes, the real mechanical advantage is only about  $6\frac{1}{2}$ , instead of 18.

To explain the reason why the load does not descend of its own accord, let us suppose for a moment that our grammes are lbs. and that the load has been lifted through 1 ft. To raise the load C (450 lbs.) through 1 ft., requires 450 foot-lbs., but we have used 1,260 foot-lbs. for this is the product of the power load of 70 lbs. moving through a distance of 18 ft.; therefore 810 foot-lbs. have been absorbed by friction. The total load depending from the upper pulley block is 520 lbs., (450+70), and practically the

entire amount of friction present in the model is produced by the pressure of this load upon the axle F. Of this total (520 lbs.), the power load of 70 lbs. contributes only  $\frac{7}{52}$ , which for convenience we will call  $\frac{1}{7}$ th of the total.

Now let us remove the power load. By so doing we diminish the pressure on F by  $\frac{1}{7}$ th, and consequently reduce friction by  $\frac{1}{7}$ th, so that friction now equals 694 lbs. It will be seen that the load is unable to descend unless we aid it by hauling on the chain at B, for the energy it exerts in falling (namely, 450 foot-lbs.) cannot overcome the friction. 810 foot-lbs. were required to overcome the friction in raising the load, and because  $\frac{6}{7}$ ths of the friction is still present, 694 foot-lbs. ( $\frac{6}{7}$ th of 810) would be necessary to overcome friction in the descent.

The principle set out above may be applied to other mechanical powers. Whenever more than half of the applied energy is uselessly absorbed by friction, the load will remain suspended without overhauling.

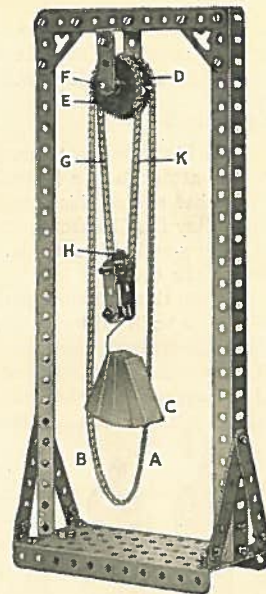

Fig. 6

Differential Pulley Block

for convenience we will call  $\frac{1}{7}$ th of the total.

## Section III. Pulleys and Pulley Blocks—(continued)

### S.M. 32—TWO-SHEAVE PULLEY-BLOCK

The block is constructed from three  $2\frac{1}{2}$  in. Triangular Plates (1) held together by  $\frac{3}{4}$  in. Bolts (2). Two 1 in. loose Pulleys are pivoted on the axle (3), journaled through the centre holes of the plates and fitted with Collars on each end. Four Washers (4) are placed on the Bolts (2) between the Plates (1) in order to ensure clearance for the pulleys, round which the winding cord (5) passes. The Hook (6) is carried from the lower bolt by means of the Flat Bracket (7). Theoretical mechanical advantage ; four.

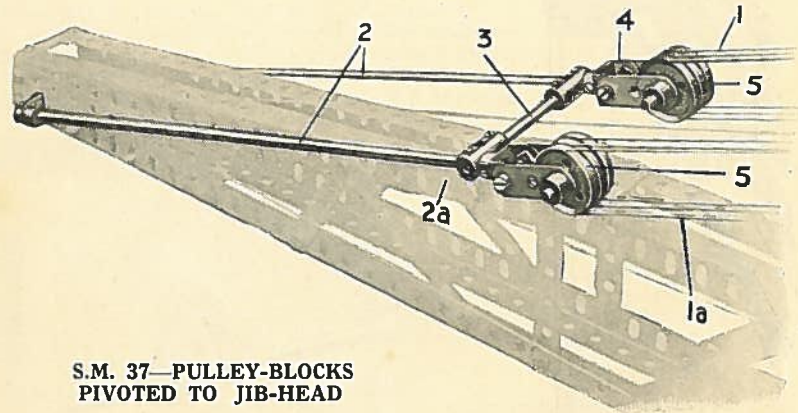

S.M. 37—PULLEY-BLOCKS  
PIVOTED TO JIB-HEAD

From this illustration it will be seen that the pulley blocks (4) are bolted, by means of Fork Pieces, to the tie-rods (2) secured to the end of the jib (2A). A strut (3) constructed from a short Rod mounted in Couplings, holds the tie-rods in position.

Each pulley block contains three sheaves (5). Two separate hoisting cords (1 and 1A) are employed, the running ends of each being secured to the winding-drum in the model. The other ends pass round the sheaves (5) and corresponding sheaves in the immovable blocks secured to the model, and are finally tied to their respective fixed blocks.

The operation of the cords (1, 1A) is similar to that shown in S.M. 31. Because both running ends are hauled in together, the mechanical advantage also is the same as in that example, but by duplicating the mechanism we are able to safely use increased power and consequently raise greater loads.

### S.M. 36—THREE-SHEAVE PULLEY-BLOCK

This is another type of pulley block having the same mechanical advantage as those shown in S.M. 31 and 37. Four Washers should be placed on the lower Axle Rod between the Strips, in order to obtain sufficient clearance for the rotating sheaves.

S.M.  
32

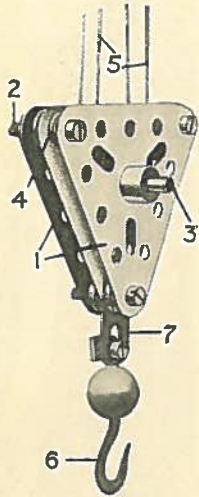

### S.M. 33-35—SINGLE MOVEABLE PULLEYS

We illustrate three types of Meccano single pulley tackle. In each case one end of the cord is secured to the tail of the standing block and the other end is rove through its pulley and leads down as the running or hauling-end.

In each of these three arrangements the mechanical advantage is two, that is to say a 100 lb. weight should (theoretically) be lifted with a force of 50 lb. (See Example 2 in this section).



S.M. 33



S.M. 34



S.M. 35



## Section III. Pulleys and Pulley Blocks—(continued)

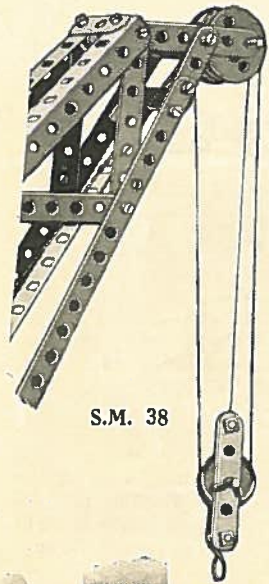

S.M. 38

**S.M. 38—MOVEABLE PULLEY-BLOCK FOR CRANE**  
 A hoisting-cord is led over one of the pulleys in the jib-head, around the sheave of a moveable pulley-block, over a second jib pulley, and back again to the moveable pulley block, where it is secured. In this way a theoretical mechanical advantage of three is obtained, for the moveable pulley is supported by three cords. Further single-sheave pulley blocks are shown in S.M. Nos. 151, 154, and 156 (Section X.)

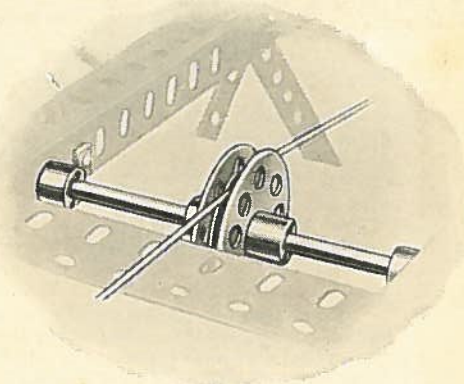

S.M. 39

### S.M. 39—GUIDE PULLEY

This is constructed by clamping a 1 in. loose Pulley between two Bush Wheels. The deep groove so obtained is a great improvement, especially when used in models where the cord is liable to be jerked off an ordinary pulley.

### S.M. 39a—DEEP-GROOVED PULLEY

A larger deep-grooved pulley may be constructed by bolting a Wheel Flange between two Face Plates. With this arrangement the cord is led round the periphery of the Wheel Flange and is held in place by the protruding edges of the Face Plates.

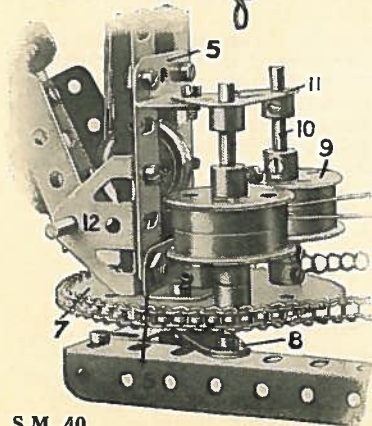

S.M. 40

### S.M. 40—GUIDE PULLEYS

Hoisting-cords may be directed to a jib-head by guide pulleys (9) constructed by butting two Flanged Wheels together. These are mounted on shafts (10) journaled in a Corner Bracket (11) and in two holes of a 3 in. Sprocket Wheel (7).

As the jib (5) swings about its pivot (8) the cords are retained in line with the 1" pulleys shown by one or other of the guides (9).

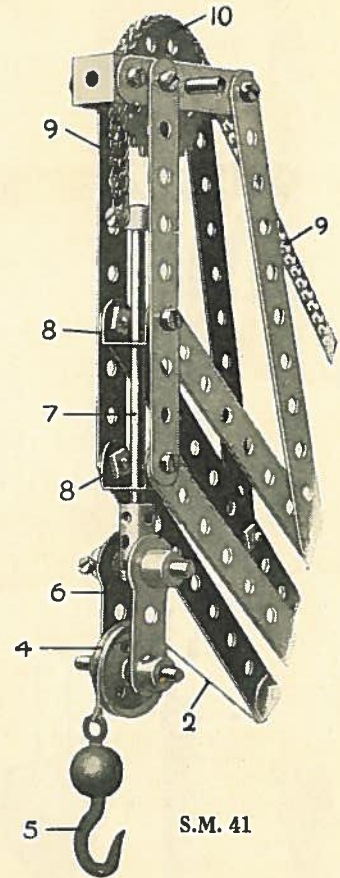

S.M. 41

### S.M. 41—VARIABLE PULLEY-BLOCK

A 1 in. Pulley (4), from which a load hook (5) is suspended, is carried in two Cranks (6) connected to a 3½ in. Rod (7) slideable in two Double Brackets (8). The Rod (7) is supported by the Sprocket Chain (9) to which it is connected by a Collar and Set Screw.

By attaching the other end of the chain to some resistance, such as a Meccano Spring, the weight of a load on the Hook (5) may be calculated by noting the distance through which the Chain is pulled. The movement of the Chain may be employed to operate a suitable indicator, such as a pointer with graduated dial similar to that provided in Model No. 627, Automatic Weighing Crane.

## Section IV. LEVERS

shows the beam pivoted in its fifth hole, 125 grammes and two  $2\frac{1}{2}$ " strips are found necessary to balance AP.

### Example 1.

It will now be found that a power load of 50 grammes at B is sufficient to balance a load of 200 grammes at C; therefore this arrangement of the simple lever gives a mechanical advantage of four. The arm AB is 8 in. in length and CA only 2 in. As the radius of the point B from the fulcrum A is four times as great as that of the point C, point B must move through a distance four times greater than that through which the point C moves. This explains the mechanical advantage obtained in our model, for we have already seen (Example 2, Section III.) that a power is increased proportionally to the distance through which it moves.

### Example 2.

We may further prove this rule by changing the position of the power F to the point G, which is four inches from the fulcrum A. A power of 100 grammes is now found necessary to balance the load D, for G moves through a distance only twice as great as C.

### Example 3.

The rule may be expressed more generally by stating that the power is to the load as the distance of the load from the fulcrum is to the distance of the power from the fulcrum. By applying the rule, we may ascertain the power required to raise any given load, providing we know the lengths of the two arms of the lever.

Suppose for example, that it is desired to raise the load at C (200 grammes) by applying a power at the point P in the lever. The distance of the load (C) from the fulcrum (A) is 2 in., and the distance of the power P from the fulcrum (A) is 10 in. Therefore CA is only one fifth as great as AP; and since the power is to the load as CA (the distance of the load from the fulcrum) is to AP (the distance of the power from the fulcrum), then the power required is only one fifth as great as the load. Hence we find that 40 grammes at P will balance 200 grammes at C.

Further interesting experiments may be carried out with this model by a taring the positions of the power and load, or by moving the fulcrum in either direction along the lever. In the latter case, it should be remembered that the weight E must be readjusted to balance the altered length of the arm AP.

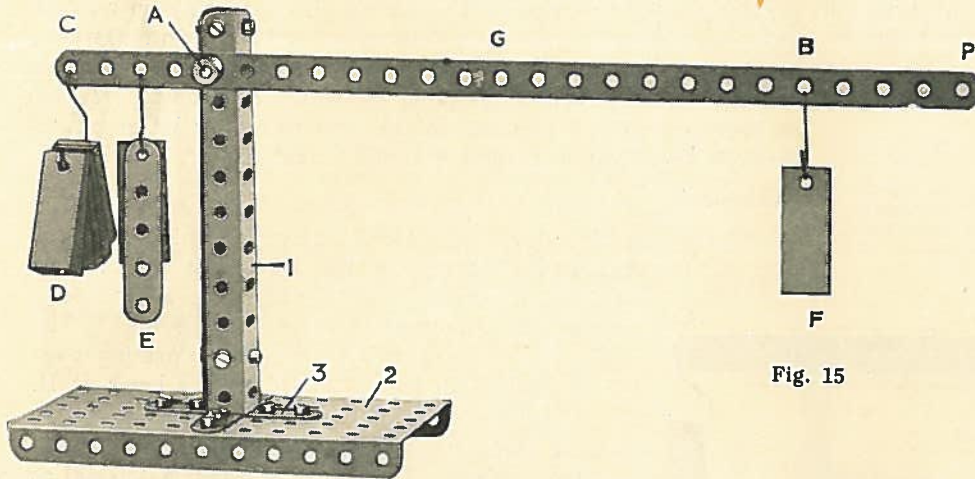

Fig. 15

### LEVER OF THE FIRST ORDER

THE lever is the simplest and perhaps most valuable of the various mechanical powers, for it forms a useful medium for increasing or changing the direction of a force in cases where it would be impracticable to employ pulleys. The lever is classed in three distinct groups, and is said to belong to the first, second, or third "order," according to the relative position of the fulcrum, or point at which the lever pivots, to the "power" and the "load."

A lever of the first order is illustrated in Fig. 15. The upright member of this model is constructed from two  $5\frac{1}{2}$ " Angle Girders (1) secured to the base (2) by  $1" \times 1"$  Angle Brackets (3) and held together at their tops by two  $\frac{1}{2}" \times \frac{1}{2}"$  Angle Brackets. A short Rod, which supports the lever, is passed through the upright and rigidly secured in a Crank bolted to the rear  $5\frac{1}{2}"$  Angle Girder.

As will be seen, the fulcrum A is situated between the load D and the power F. In order to experiment with the properties of the lever, we must first counterpoise the weight of the arm AP. This may be done by adding a weight E to the arm AC, and in the example illustrated, which

## Section IV. Levers—(continued)

### LEVER OF THE SECOND ORDER

In levers of the second order, the fulcrum is at one end, the power at the other, and the load lies between the two. This type of lever is shown in Fig. 16, in which A is the fulcrum, B the point at which the load D is applied, and C is the power.

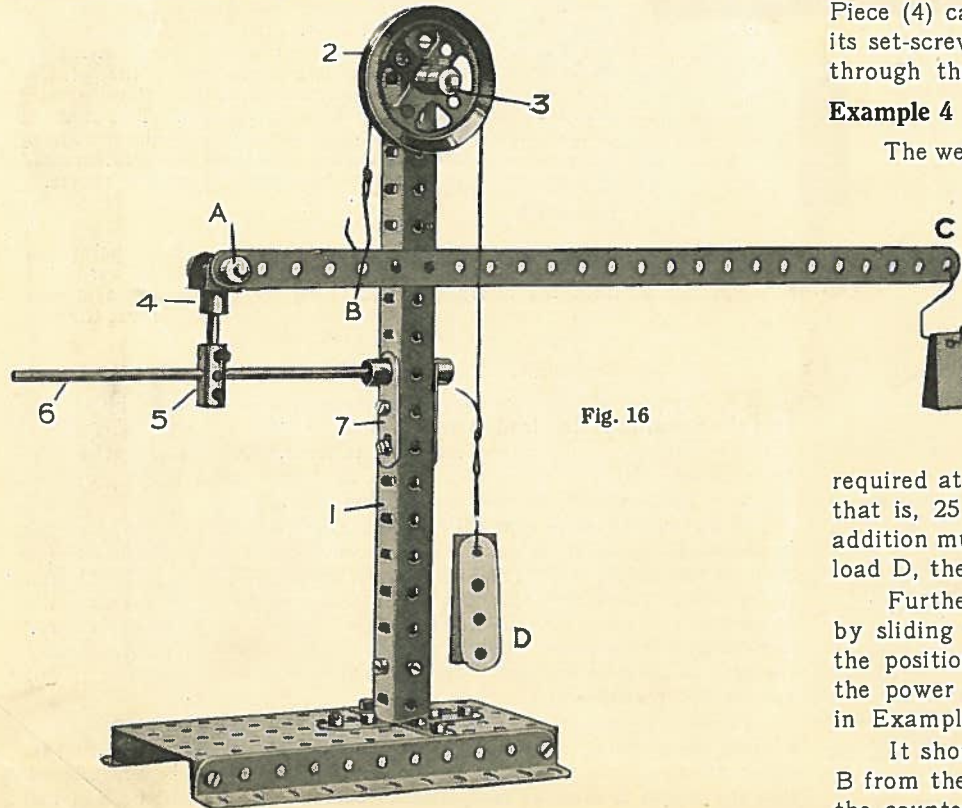

Fig. 16

The upright column (1) in this example is constructed in a similar manner to that shown in Fig. 15, but in this case the Girders are  $9\frac{1}{2}$ " in length. The Pulley (2) runs freely on a short axle, and is held in place by a Collar (3). A  $12\frac{1}{2}$ " Strip represents the lever, and pivots about a short axle journalled in a Fork Piece (4) carried from a Coupling (5) which may be secured by its set-screw in any position on the Rod (6). The latter passes through the upright Girders (1) and is secured in Cranks (7).

#### Example 4

The weight of the lever AC is balanced by placing 100 grammes and one 2" Strip on the load-hook at D. In addition to these weights, the hook D carries a further 150 grammes to represent the load. The load-hook is suspended from a cord passing over the 2" Pulley (2) and attached to the lever at B.

The power C is 12 in. from the fulcrum A, and the point B, at which the load D takes effect, is 2 in. distant. Therefore AC is six times as great as AB, and by applying the rule set out in Example 3 in this Section, we know that the power required at C to balance the load D is one sixth of 150 grammes, that is, 25 grammes. It will be found, however, that a slight addition must be made to the power C in order to actually raise the load D, the weight added representing the force lost by friction.

Further experiments may be carried out with this model by sliding the Coupling (5) along the Rod (6) and so altering the position of the point B, or by diminishing the distance of the power C from the fulcrum. In each case the rule set out in Example 3 will be found equally applicable.

It should be noted that whenever the distance of the point B from the fulcrum is changed, it will also be necessary to alter the counterpoise on the load-hook.

## Section IV. Levers—(continued)

### LEVER OF THE THIRD ORDER

In levers of the third order the fulcrum is at one end, the load is at the other end, and the power lies between the two.

This type of lever, which is illustrated in Fig. 17, is never employed when it is required to increase power; whenever it is used the power must always exceed the load. The advantage gained in its use is the fact that the power moves through a smaller space than the load. For this reason levers of the third order are usually employed as foot-treadles in such machines as lathes, grind-stones, etc., where the power is applied by the foot between the fulcrum at one end of the lever, and the load, or power required to move the crankshaft, at the other end.

The construction of the model is very similar to that shown in Fig. 16, except that in this case the lever is a  $9\frac{1}{2}$ " Strip, suspended from an  $11\frac{1}{2}$ " Rod secured in the upright  $9\frac{1}{2}$ " Girders.

#### Example 5

The load D is suspended from a cord passing over a 2" Pulley and attached to the lever at C, the power B lying between this point and the fulcrum A. Three  $2\frac{1}{2}$ " Strips, which act as a counterpoise to the weight of the arm AC, are added to the load hook at D.

It will be seen that the distance of the load from the fulcrum is twice as great as the distance of the power from the fulcrum. Therefore the power, according to the principle of energy (Example 1 in this Section), must be twice as great as the load.

The same conclusion may be arrived at by means of the rule set out in Example 3. Supposing the load D to be 50 grammes, the power required to balance it may be ascertained as follows. The distance of the point C (at which the load is applied) from the fulcrum is 9 in., and that of the power B is  $4\frac{1}{2}$  in.; therefore AC is twice as great as AB. The rule states that the power is to the load as AC (the distance of the load from the fulcrum) is to AB (the distance of the power from the fulcrum). As the power must therefore be twice as great as the load, the power required is 100 grammes.

#### Example 6

Again, we will assume that the load D of 50 grammes is to be raised by a power applied at a point E in the lever. As the distance from A to E is 3 in. and that from A to C 9 in., AC is three times as great as AE. Hence, by the same calculation as above, the required power is found to be 150 grammes.

Actual experiments will prove all the results arrived at from these simple deductions are perfectly correct.

NOTE. It may be mentioned that the weights used in these experiments are listed in the Meccano Accessory Parts list. They are supplied in two sizes, 25 and 50 grammes (Parts Nos. 66 and 67) and are included in the Price List at the end of this book.

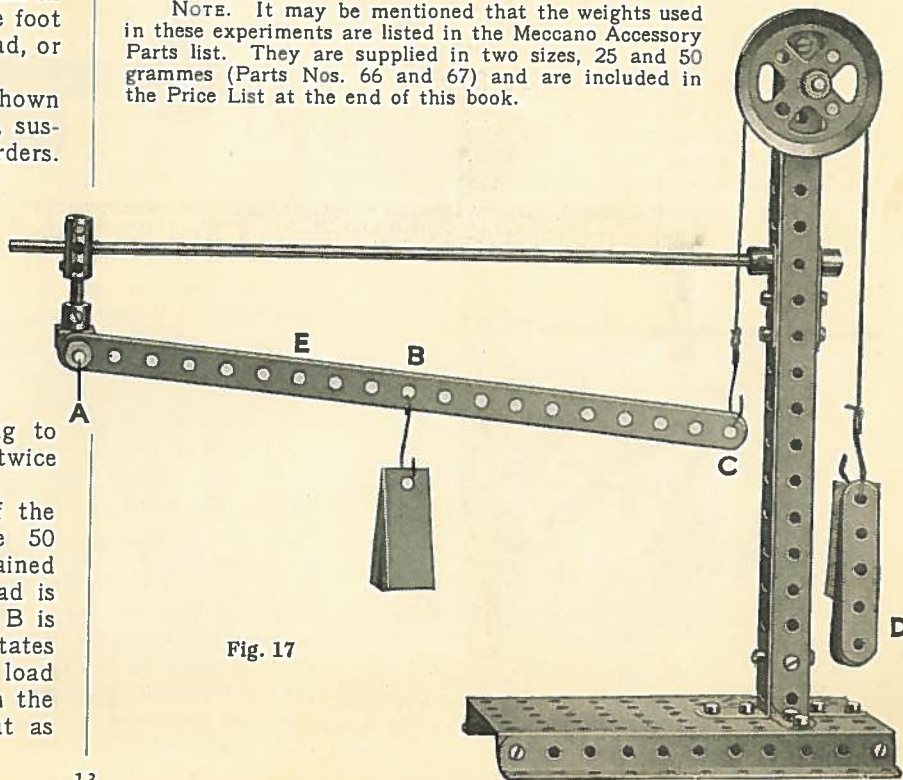



## Section IV. Levers—(continued)

### EXAMPLES OF THE LEVER AS ADAPTED TO MECCANO MODELS

The various applications of the lever as a means of modifying or transforming power in weighing machines are well known. Fig. 18 illustrates the lever of the first order applied to the simple steelyard, or Roman Balance. With this ingenious arrangement, which was known and used in the earliest days of civilization, a heavy load attached to the short arm of the lever may be balanced by a smaller weight sliding on the longer arm.

#### LEVERS IN PLATFORM SCALES

S.M. 51 shows the arrangement of levers in the base of the Platform Weighing Machine. The weight of the Platform, which represents the power, bears upon the first levers at C and D, between the load—represented by the force required to pull down the Sprocket Chain at A—and the fulcrum on a Hook B.

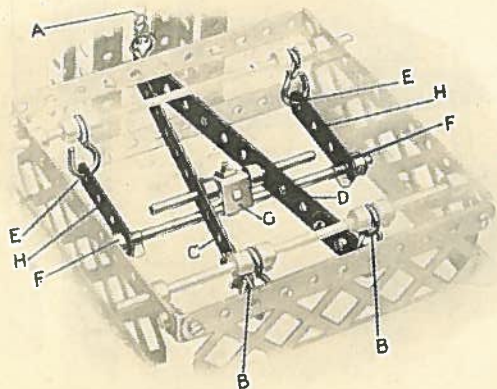

S.M. 51

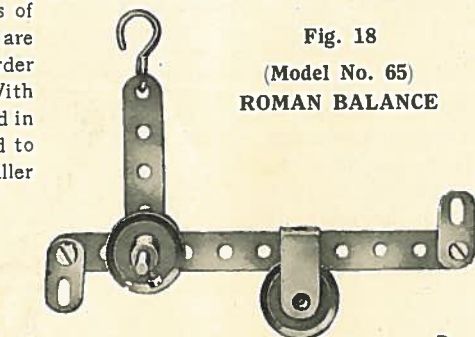

Fig. 18  
(Model No. 65)  
ROMAN BALANCE

In the smaller levers the fulcrum E is at one end, the load (or force required to pull down the centre link G) is at the other end F, and the power—i.e., the weight of the platform—bears upon H.

From this it will be seen that all these levers are of the third order and therefore the power must be greater than the load before they can be operated, as explained on page 13. Hence the pull upon the Hook A (which we have taken as representing the load) is always less than the

weight, or power, imposed upon the platform of the scales. Moreover, the load A moves through a greater distance than the power, and this proves a considerable advantage in our model.

#### LEVERS IN DRAWBRIDGE

An interesting example of the use of levers in bridges is furnished in the Meccano Drawbridge, Model No. 642.

As will be seen from Fig. 19, there are two kinds of levers included in this model. A lever of the first order is shown at ABC, the fulcrum being at B, the load at A, and the power at C. DEF represents a lever of the second order, in which F is the fulcrum, E the power, and the load is represented by the weight of the arm DE.

It will be noticed that with this arrangement of levers the bridge DF moves through a much greater distance from that traversed by the power C.

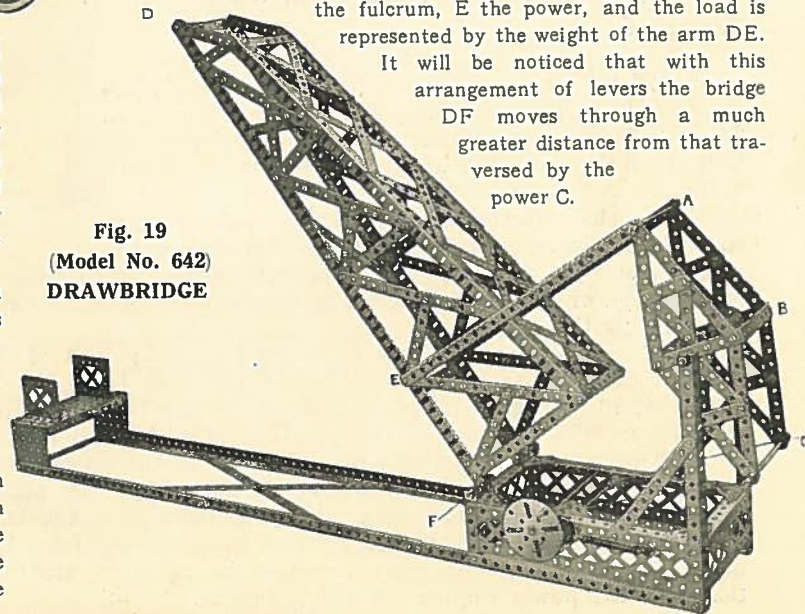

Fig. 19  
(Model No. 642)  
DRAWBRIDGE

## Section IV. Levers—(continued)

### EXAMPLES OF THE LEVER AS ADAPTED TO MECCANO MODELS

Fig. 20

In Model No. 251, Cutting Machine (Fig. 20) is included two levers of the second order. In the first lever ABC, the power is applied at A, the fulcrum is at C and the load lies between the two at B. In the second lever DE, the power is applied at D, while the fulcrum is at E.

The load in this case is represented by the pressure of the lever arm against the material to be cut, which is placed in position at F.

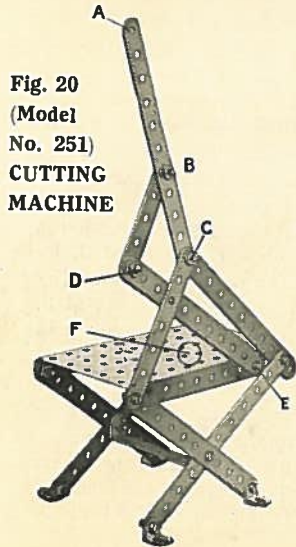

Fig. 20  
(Model  
No. 251)  
CUTTING  
MACHINE

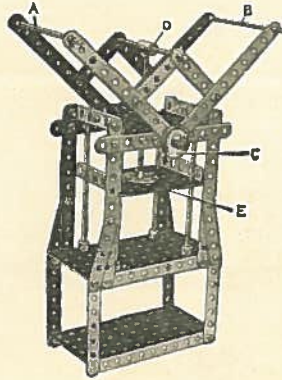

Fig. 21

Two pairs of levers of the second order are used in Model No. 430, Bale Press (Fig. 21), increasing the power applied at the points AB to a considerable extent.

These levers move about a common fulcrum at C and are all pivotally connected to a vertical sliding Rod D. The latter Rod presses the plate E against the bale and this pressure represents the load on the levers.

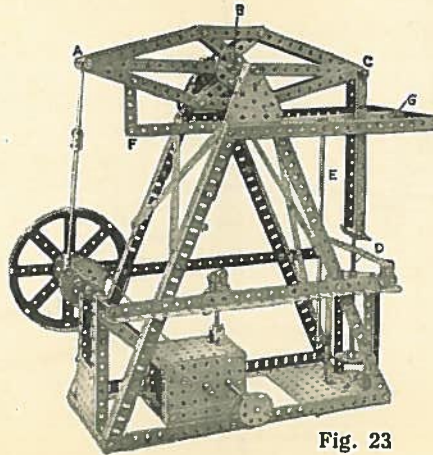

Fig. 23

Fig. 23

A very interesting expression of lever mechanism is also found in the Beam Engine, Model No. 609. As will be seen from Fig. 23, a lever of the first order, AC, is used in this model to transmit a reciprocating force at D to a crankshaft. The valve rod E is operated by means of a lever

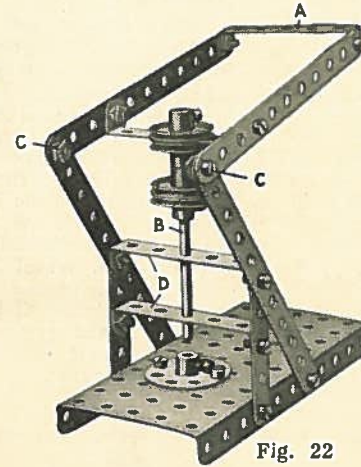
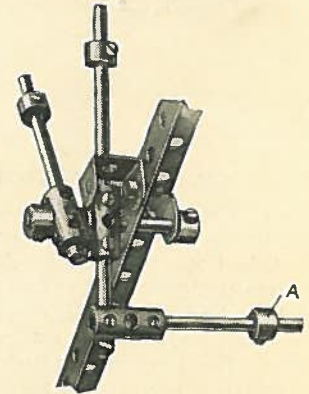

Fig. 22

Fig. 22

A single pair of levers of the second order are employed in the Punching Machine, Model No. 52 (Fig. 22) for a similar purpose to that in the previous example. A power applied at A is brought to bear with increased force on a vertical shaft B, representing the punch.

The levers are pivoted by means of bolts and lock nuts at the points C, and the punch slides in Double Angle Strips D.



S.M. 52

Examples of gear-change and brake levers fitted to the Meccano Motor Chassis.

of the second order FG.

In the latter, F represents the power, derived from the movement of the first lever AC, and the fulcrum is at G, to which the lever is pivoted by means of bolt and lock nuts. The force required to move the valve rod E up and down represents the load.

## Section V.

# CLUTCHES, REVERSING & DRIVE-CHANGING MECHANISM

S.M. 62—CLUTCH

This type of clutch is shown fitted to the Meccano Chassis. The clutch is operated by means of the foot pedal 6 pivoted on the shaft 5, which on being pressed down, slides the Rod 2, to which it is connected by the Double Bracket 7 journalled between the Collar and set screw 8 and the boss of the Bush Wheel 9.

As the Rod 2 slides in its bearings the Threaded Pins 10 bolted to the Bush Wheel 9 are thrust further into the holes of the  $1\frac{1}{2}$ " Pulley 11, and at the same time the Bevel Wheel 4 is drawn out of gear with a second Bevel Wheel 3 on the driving shaft 1. Immediately the pressure relaxes on the pedal 6 however, the counter shaft 2 is pushed back into its former position by the springs 12 (extracted from the Meccano Spring Buffers), and the bevel drive 3 and 4 is again brought into gear.

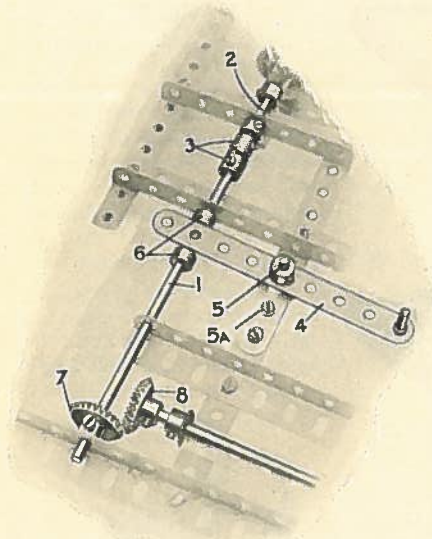
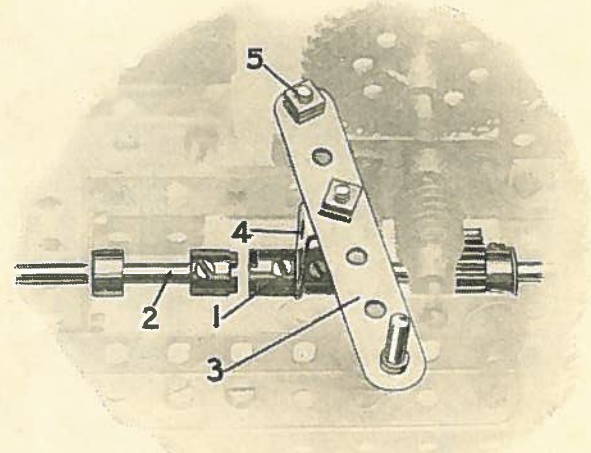

S.M. 61—DOG CLUTCH

The jaws of the Dog Clutch 3, carried on the ends of the two Axle Rods 1 and 2, are brought into engagement on operation of a lever 4, which is pivotly mounted on a short Rod 5 secured in a Crank 5A.

The lever rests between two Collars 6 mounted on the shaft 1. This shaft slides in its bearings, and its movement, in addition to combining the clutch members 3, throws a Bevel Wheel 7 in or out of gear with a similar wheel 8.

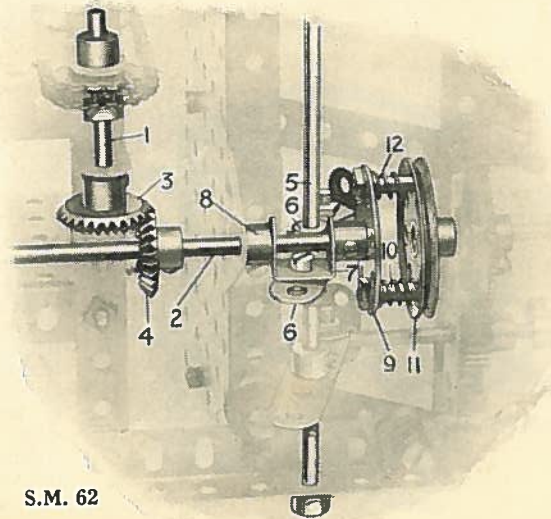

S.M. 62

S.M. 63—DOG CLUTCH

This detail provides another illustration of Dog Clutch mechanism. The clutch member 1, carried on a short Rod which is slideable in its bearings, is brought into engagement with the clutch jaws mounted on a further Rod 2, by means of a lever 3. The latter is pivoted (by bolt and lock-nuts) to an Angle Bracket at 5, and also to a Single Bent Strip 4 loosely held between the clutch segment 1 and a Collar and set screw.

A considerable improvement is effected by connecting a Spring to the lever 3, in such a manner that it normally holds the clutch members together. This Spring re-engages the shaft 2 immediately pressure is relaxed on the lever 3.

## Section V. Clutches, Reversing and Drive-Changing Mechanism—(continued)

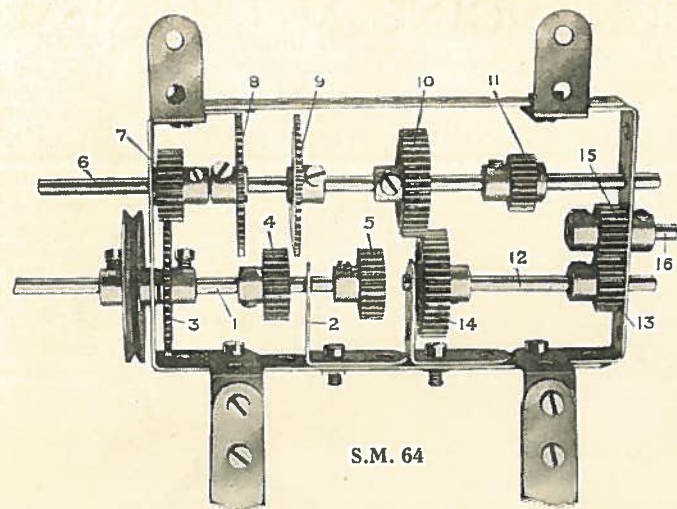

S.M. 64

S.M. 64—DRIVE-CHANGING AND REVERSING GEAR

S.M. 64 illustrates a compact example of gear box, which provides two speeds and a reverse gear. The model serves well in demonstrating the type of gear box usually fitted to automobiles.

The shaft 1 takes up the drive from the engine. This shaft, which is journaled through one end of the gear box and further supported by a 1" x 1" Angle Bracket 2, carries a 50-teeth Gear Wheel 3 and two  $\frac{3}{4}$ " Pinions 4 and 5. A secondary shaft 6 is also inserted in the gear box and carries one  $\frac{3}{4}$ " Pinion 7, two 50-teeth Gear Wheels 8 and 9, one 1" Gear Wheel 10 and one  $\frac{1}{2}$ " Pinion 11. A further shaft 12 is next mounted in position, and its other end carries the drive to the road wheels. The Rod 12 carries a  $\frac{1}{2}$ " Pinion 13 and a 1" Gear Wheel 14. A  $\frac{1}{2}$ " Pinion 15 secured to a 1" Rod 16 gears with the Pinion 13.

A lever should be next assembled, and serves to slide the shaft 6 in its bearings. A suitable lever for this purpose will be found in S.M. 52, and on reference to this detail it will be seen that the Rod A, connected at right angles to the lever by means of a Coupling, may readily be mounted as to lie transversely across the shaft 6, with its Collar engaging between the Gear Wheels 8 and 9. A movement of the lever will then push the Rod 6 in either direction as required.

The first position of the Rod 6 provides for a "top" speed, and in this position the Pinion 7 is in engagement with the Gear Wheel 3, Gear Wheels 10 and 14 are in engagement, while the Gears 8, 9 and 11 are all free. In this manner the Gear 3 causes the Pinion 7 on the secondary Rod 6 to revolve twice as fast as the primary Rod 1, and the propeller shaft 12 rotates at the same speed as the shaft 6, since it is driven from that shaft through the one-to-one Gear 10 and 14. The Pinion 15 revolves idly in this position.

For slow speed the shaft 6 is moved along until the Pinion 7 is out of engagement with the Gear Wheel 3 and the Gear 8 meshes with the Pinion 4, while Gear Wheels 10 and 14 are still engaged. With this arrangement the driving shaft 1 will revolve twice as fast as the driven shaft 12.

A reverse gear is obtained by sliding the Rod 6 still further, until the Gear Wheel 9 is in engagement with the Pinion 5 and the Pinions 11, 15 and 13 are all in mesh.

S.M. 65—DRIVE-CHANGING AND REVERSING GEAR

A Crank 1, secured to the vertical shaft 2, carries a short Rod 3 loosely journaled in a Coupling 4 also secured to the shaft 2. The short Rod 3 protrudes slightly from the lower Collar 5 and enters a hole in the Bush Wheel 6 bolted to the Plate 7. The Rod 2 is loosely journaled through this Bush Wheel 6 and engages, by means of the Pinion and 57-teeth Gear Wheel 8 and 9, a further Rod 10. The latter carries in a Coupling 11 a short Rod 12 which engages between two Collars 13 on an intermediate driving shaft 14. This shaft 14 is thus moved to and fro in its bearings by lifting the Collar 15 and moving the Crank 1 to left or right until the Rod 3, actuated by a small spring 16 (extracted from the Meccano Spring Buffer, Part No. 120A), snaps home into the next hole of the Bush Wheel 6. The central position of the Rod 2 enables the shaft 14 to revolve freely, but the movement of the Rod to the next hole in the Bush Wheel brings the Pinion 17 into gear with another Pinion 18, whilst a move of one hole in the opposite direction brings further Pinions (not shown in the photograph) secured to shaft 14 into engagement with Gear Wheels carried on a further driven shaft (also not shown).

Thus this movement may be utilised (a) to throw the Motor out of gear with—say—the road wheels of a tractor, (b) to drive the same forward at reduced speed, and (c) to reverse the direction of their rotation.

It should be noted that in our illustration a side plate corresponding to that shown at 19 has been removed in order to disclose the mechanism. Normally this plate is bolted to the Girders 20 and 21 and so forms a bearing for the shaft 14.

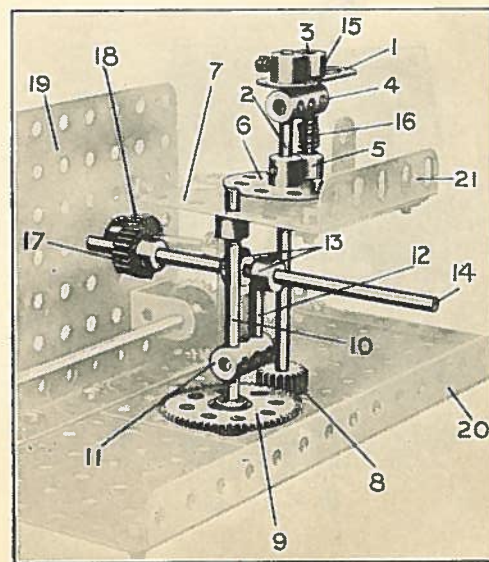

S.M. 65

## Section V. Clutches, Reversing and Drive-Changing Mechanism—(continued)

### S.M. 66—REVERSING GEAR

The driving shaft 1 is caused to engage a  $\frac{1}{2}$ " Pinion on the secondary shaft 2 through one or other of the  $\frac{1}{4}$ " Contrate Wheels 3 and 4.

The change is effected by a lever 5 pivoted to a Double Bent Strip 6 and carrying a  $1" \times 2\frac{1}{2}"$  Double Angle Strip 7, through which the driving shaft 1 is journallèd. The Double Angle Strip is held in place on the Rod 1 by means of Collars and Set Screws 8. The direction of rotation of the Rod 2 varies according to the Contrate Wheel which drives it.

Bevel Wheels may be employed with equal facility in place of the  $\frac{1}{2}$ " Pinion and Contrate Wheels 3 and 4. See S.M. 131.

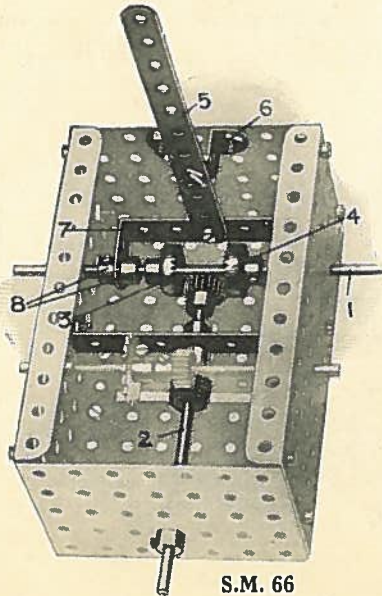

S.M. 66

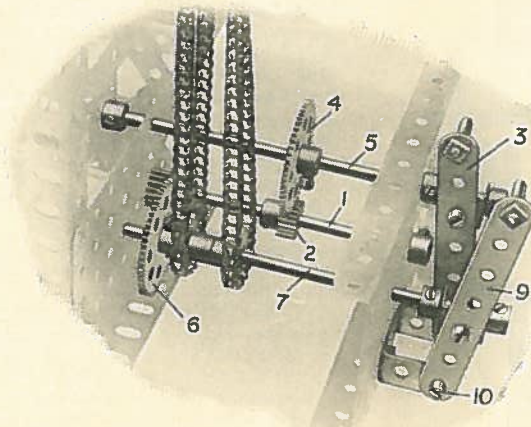

S.M. 67

### S.M. 68—DRIVE-CHANGING GEAR FOR OVERHEAD TROLLEY

The gear-change is operated by means of cords 3, secured to a Boss Bell Crank 2, and hanging to convenient handling position below the rails upon which the trolley runs. The Crank 2 rocks the axle 1 which engages the Worm Wheel 5 through a Pinion 4. The Worm Wheel is secured to a Rod 6 and so acts as a rack by means of which this Rod may be moved to and fro.

A driving Rod 8 is caused to imitate the movements of the Rod 6, the method of connection comprising a Crank 7 engaging between two Collars. This Rod 8 carries two Pinions 9 and 10 which, in consequence of the movement of Rod 6, may be brought into engagement with one or other of the Gears 11 and 12. In the model illustrated, the Gear 11 causes the trolley to traverse the rails, while the Gear Wheel 12 operates the hoisting cord of the pulley-block; the driving Rod 8 is rotated by hauling on an endless chain 13.

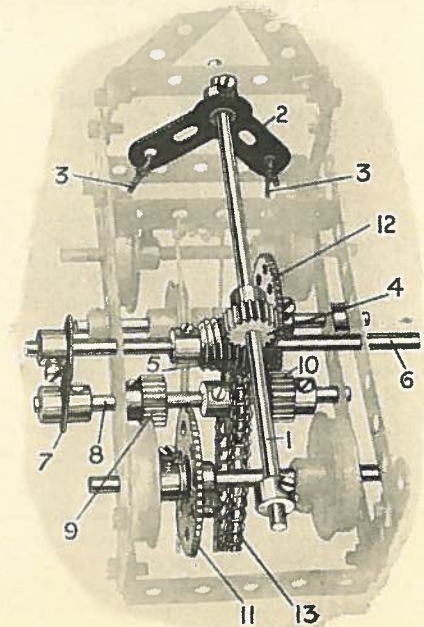

S.M. 68

# Section V. Clutches, Reversing and Drive-Changing Mechanism—(continued)

## S.M. 69—DRIVE-CHANGING GEAR

The Rod 1 slides in its bearings and is controlled by a lever 2, which is pivoted at 3 and rests between two Collars and Set Screws 4 on the sliding Rod 1. The latter carries a Crank 5, the web of which engages

between two Bevel Wheels 6 secured to a short Rod 7 driven from the Motor 8, as shown in the sectional illustration (S.M. 69A). The Crank 5 is suitably spaced with Washers 5A.

On operation of the lever 2, one of the Bevel Wheels 6 may be brought into gear with one or other of the two further Bevel Wheels 9 mounted on secondary shafts 10. This provides for two independent drives, either of which may be connected with the Motor by moving the lever 2.

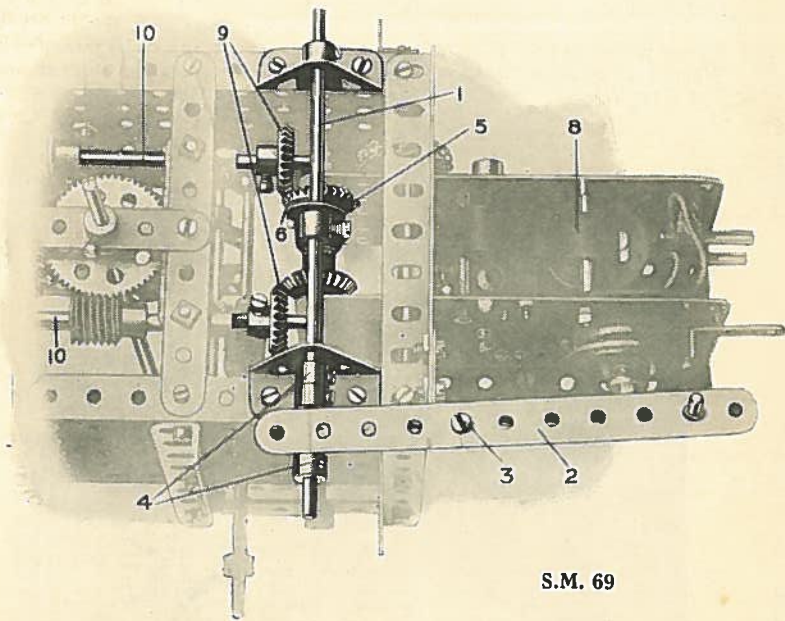

S.M. 69

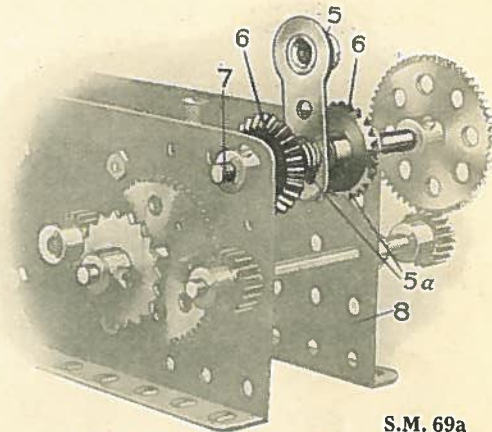

S.M. 69a  
Detail of Drive-Changing Gear (S.M. 69)

## S.M. 70—DRIVE-CHANGING GEAR

The driving Pulley 1 is mounted on a shaft 2 carrying a  $\frac{3}{4}$ " Pinion 3 and  $\frac{1}{2}$ " Pinion 4. These Pinions may be thrown in or out of engagement with the 50 and 57-teeth Gear Wheels 8 and 9 by sliding a handle 5, the Rod 6 of which carries a Crank 7 loosely journaled on the Rod 2 between the Pinion 4 and a Collar and set screw 10.

The Pinions 3 and 4 are so arranged on the shaft 2 that they cannot engage their respective Gear Wheels at the same time. This means that as one of the Pinions is moved into engagement with its Gear Wheel, the other is automatically thrown out of gear, and *vice-versa*.

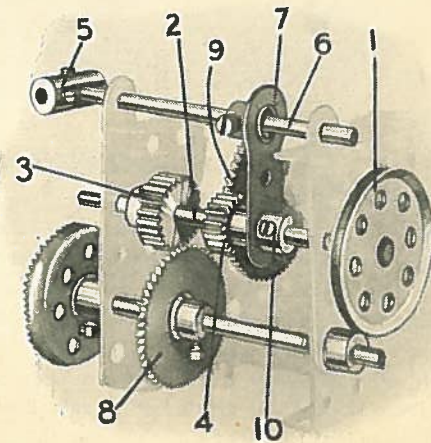

S.M. 70

## Section V. Clutches, Reversing and Drive-Changing Mechanism—(continued)

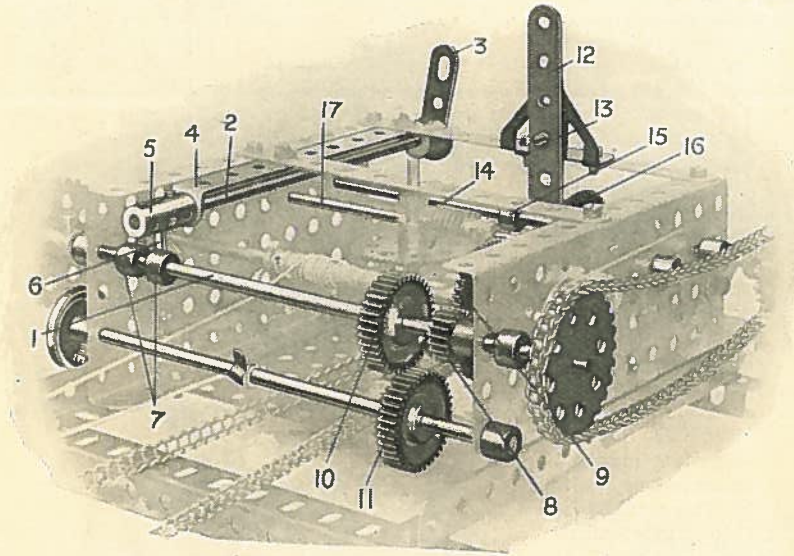

S.M. 71

### S.M. 71—DRIVE-CHANGING GEAR

The counter-shaft 1, which takes the drive from the Motor, is moved to and fro in its bearings by means of a Rod 2 actuated by a Crank 3 and journalled in a Double Angle Strip 4. This Rod 2 carries a Coupling 5 in which is mounted a short Rod 6 engaging between two Collars 7 on the shaft 1. The movement of the shaft 1 brings the  $\frac{1}{2}$ " Pinion 8 into gear with a Gear Wheel 9, or the 1" Gear Wheel 10 into gear with a similar wheel 11, as desired.

A third drive, included in this gear box, may be brought into operation on moving a lever 12, which is pivoted at 13 and slides a Rod 14, so bringing a  $\frac{1}{2}$ " Pinion secured to that Rod in or out of engagement with a Gear Wheel 16, mounted on another Rod 17. The lever 12 rests between two Collars (one of which is seen at 15) secured to the Rod 14.

### S.M. 72—DRIVE-CHANGING GEAR

On operation of the lever 1, the Rod 2 may be moved to and fro in its bearings, so causing the 57-teeth Gear Wheel 3 to engage with the  $\frac{1}{2}$ " Pinion 4 or the  $\frac{1}{2}$ " Pinion 5 with the Contrate Wheel 6.

The Gear-box shown is that fitted to the Pontoon Crane, in which the former position of the Rod 2 rotates the Crane about its axis by means of a Worm gear 7 and vertical shaft 8, while the latter position elevates the jib. The Gear Wheel 3 remains constantly in mesh with the Motor Pinion 9.

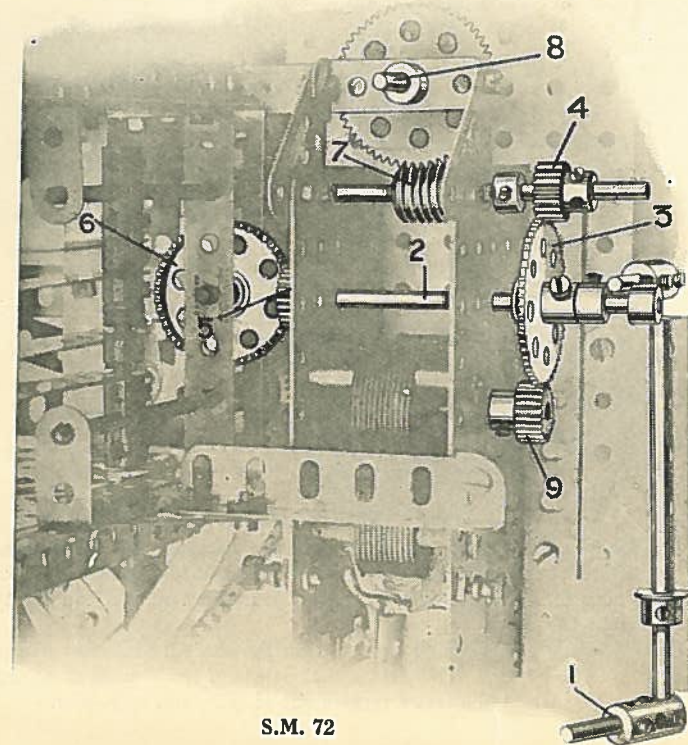

S.M. 72

# Section VI. BRAKES AND RETARDING APPLIANCES

## S.M. 81—STRAP AND LEVER BRAKE

A short cord, representing the strap which in actual practice is usually faced with leather or wood, is tied at both ends to a lever 1, and passes round the groove of the 1" Pulley 3 secured to a Rod 4.

On pressing down the lever 1, which is pivoted at 2 (see S.M. 262), the grip of the cord increases about the Pulley 3 and so retards or stops the rotation of the shaft 4.

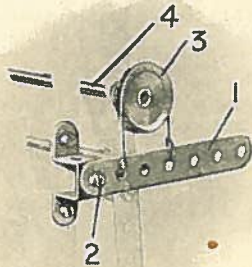

S.M. 81

## S.M. 82—STRAP AND WEIGHTED LEVER BRAKE

This brake is similar to that described in S.M. 81, except that the lever 1 carries a Flanged Wheel, which is secured by its set-screw to the shank of a bolt passing through a hole in the lever.

The weighted lever so obtained imparts a continual pressure of the cord 2 about the 1" Pulley 3, and this pressure is designed to overcome any tendency of "back-slip" in the shaft secured to the Pulley.

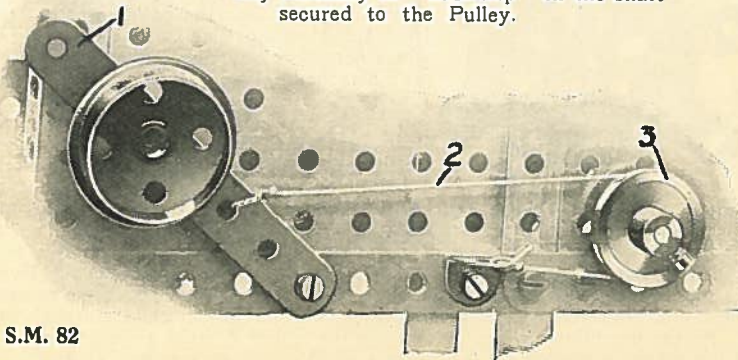

S.M. 82

## S.M. 83—STRAP AND LEVER BRAKE

This is a type of strap and lever brake adapted to the Meccano Motor Chassis. A short cord 2, passing round a 1½" Pulley Wheel secured to the back axle 1, is tied to the round hole of the Crank 3 carried from a shaft 4. This Crank 3 is connected to another Crank 7 by means of a cord 6, and the Crank 7 is bolted to a short rod secured at right angles to the foot of the hand lever 5. It will now be seen that the grip of the cord 2 about the 1½" Pulley may be increased on moving the lever 5; this gradually checks the rotation of the back axle 1. The object of the Crank 3 is to increase leverage on the cord 2.

When fitting this brake to a Motor Chassis, or similar model, a further Crank corresponding to that shown at 3 should be secured to the shaft 4 and caused to impart a retarding effect on the other end of the back axle 1 by the same means as that already shown (i.e. cord and 1½" Pulley).



## S.M. 84—PAWL AND RATCHET WHEEL

This illustrates the standard Meccano Pawl and Ratchet Wheel gear, which allows the shaft carrying the Ratchet Wheel to rotate in one direction only. The advantages of such an arrangement are obvious, especially when attached to model Cranes, hoisting-tackle, etc., where the Pawl and Ratchet gear prevents falling-back of the load as it is hoisted.

It is sometimes found advantageous to apply slight pressure on the Pawl—by means of a spring or weighted lever—to ensure its engagement with the teeth of the Ratchet Wheel.

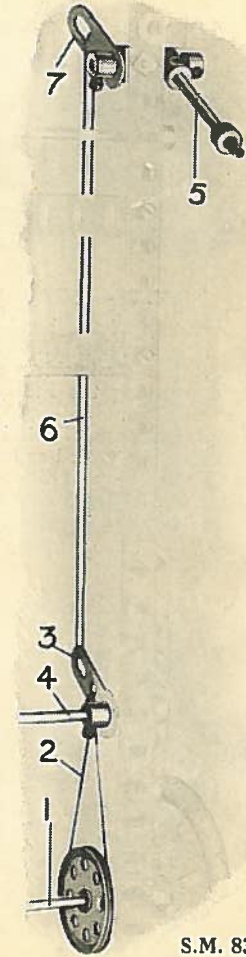

S.M. 83



## Section VI. Brakes and Retarding Appliances—(continued)

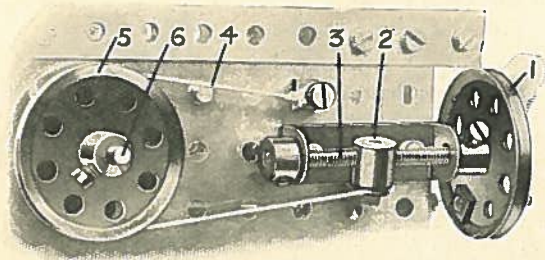

**S.M. 85—STRAP AND SCREW BRAKE**

Rotation of the hand-wheel 1 causes the Threaded Boss 6 to travel in either direction along the Threaded Rod 3, thus diminishing or increasing the grip of the cord 4 engaging the Pulley 5, which revolves with the driven shaft 6.

An advantage of this brake is that the speed of the shaft 6 may be varied as required, or the pressure of the cord 4 altered to meet different loads; the grip of the cord 4 about the Pulley 5 cannot vary when once set unless the hand-wheel 1 is turned.

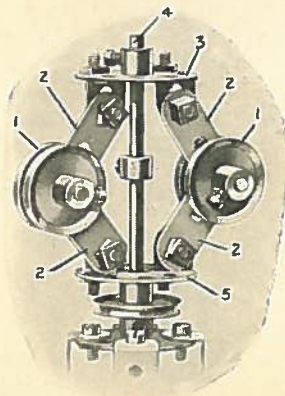

**S.M. 87**

**S.M. 87—CENTRIFUGAL GOVERNOR**

The weights 1 are carried on  $1\frac{1}{2}$ " Strips 2 pivotally connected to a Push Wheel 3 secured to the vertical Rod 4, and to another Bush Wheel 5 sliding freely upon the Rod 4. This latter Rod is driven by any suitable method from the engine or motor; as the speed at which it rotates increases, the weights 1 fly outward, with the result that the Bush Wheel 5 moves up the Rod 4. This movement of the Wheel 5 is employed to gradually apply a brake or some other retarding contrivance, so preventing any tendency of the engine or motor to "race."

**S.M. 86—SCREW-OPERATED DOUBLE BAND BRAKE**

This is an efficient type of brake which should prove useful in many Meccano models. The speed of the mechanism which it controls may be varied to accurate degrees and when fully contracted it forms a powerful and rigid brake.

Rotation of the hand-wheel 1 brings together the brake bands 2 and 3, thus applying a firm grip on the drum 4 formed from two Flanged Wheels mounted on the driven shaft. The Strip 2 is bolted to a Threaded Crank 5 engaging the Threaded Rod 6 of the hand-wheel, and the Strip 3 presses against a Threaded Boss 7. The Threaded Boss 7 revolves with the Rod 6, to which it is locked by means of a nut also mounted on the Rod 6 and screwed tight against the outer end of the Boss. The Rod 6 should be allowed sufficient play to move to and fro in its bearings as the brake bands contract or open. The brake bands are bolted at their lower ends to Double Brackets

pivotedly carried on  $1\frac{1}{2}$ " Rods. They may be lined with leather or other material at the points of contact with the brake drum, although such a lining is not essential in the Meccano model.

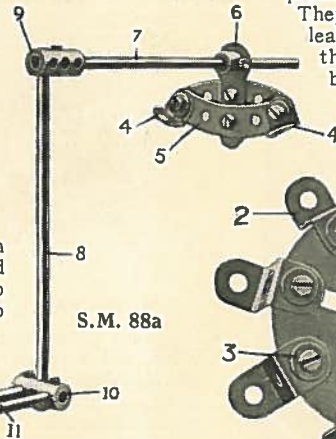

**S.M. 88a**

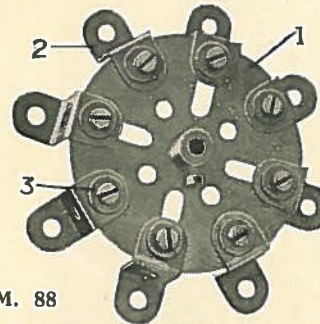

**S.M. 88**

latter is bolted on a 6" Rod 7, and a 5" Rod 8 is secured in a Coupling 10 carrying 9 on the end of the Rod 7. At the lower end of this 5" Rod is a Coupling 10 carrying two 2" Rods 11. The escapement 7 is mounted pivotally in the Clock case just above the escapement wheel, and the pendulum, suspended from a suitable pivot, passes through the fork 11. As the pendulum swings to and fro the crutch 5 rocks about its axis, so allowing the pallets 4 alternately to release a tooth of the escapement wheel 1.

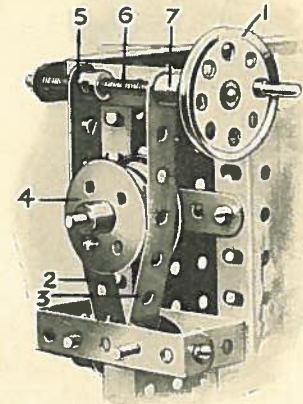

**S.M. 86**

**S.M. 88 and 88a—CLOCK ESCAPEMENT**

The commonplace, yet very ingenious, contrivance by which the speed of clock mechanism is controlled forms an interesting subject. S.M. 88 illustrates the escapement wheel, and S.M. 88a the pallets and crutch, from the Meccano Clock. The escapement wheel consists of a Face Plate 1, to which are attached eight  $\frac{1}{4}$ " Reversed Angle Brackets 2. Washers 3 are placed beneath the heads of the bolts to ensure that the Brackets 2 are held very rigidly in place. The pallets are formed from Angle Brackets 4 bolted to the crutch 5, which consists of two  $2\frac{1}{2}$ " reversed Curved Strips bolted one on either side of the web of a Crank 6. The

## Section VII. ROLLER AND BALL BEARINGS, Etc.

### S.M. 101—ROLLER BEARINGS

Where a heavy mass is to be rotated about an axis, it is necessary to devise some method of relieving the tremendous strain that would be imposed upon that axis. The usual procedure is to distribute the weight of the mass over wheels or rollers arranged at a distance from and rotating round the central pivot.

Standard Mechanism No. 101 is an excellent illustration of the type of roller, or wheel, bearings frequently used for the rotation of large cranes, revolving bridges, and other heavy structures. The lower, or stationary guide rails 1 are constructed from eight Channel Segments, and form a track upon which the wheel race 2 revolves. The fixed guide is shown in detail in S.M.101A; it will be noted that the Channel Segments are bolted to the base by means of  $1'' \times \frac{1}{2}''$  Angle Brackets 3. The Sprocket Chain 4 shown in this

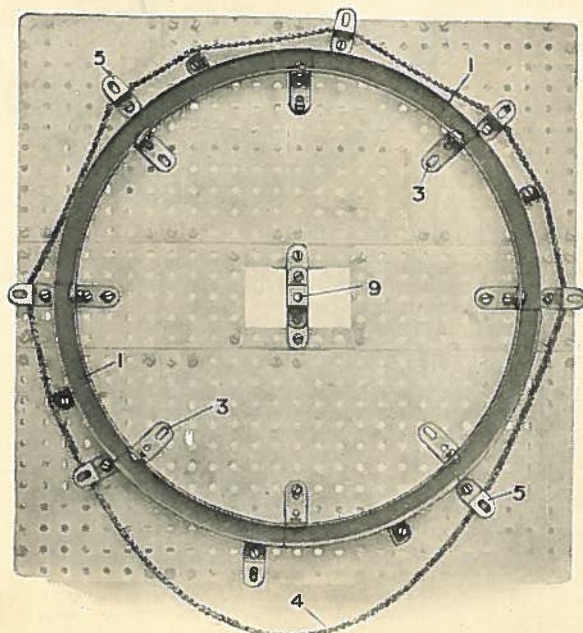

S.M. 101a

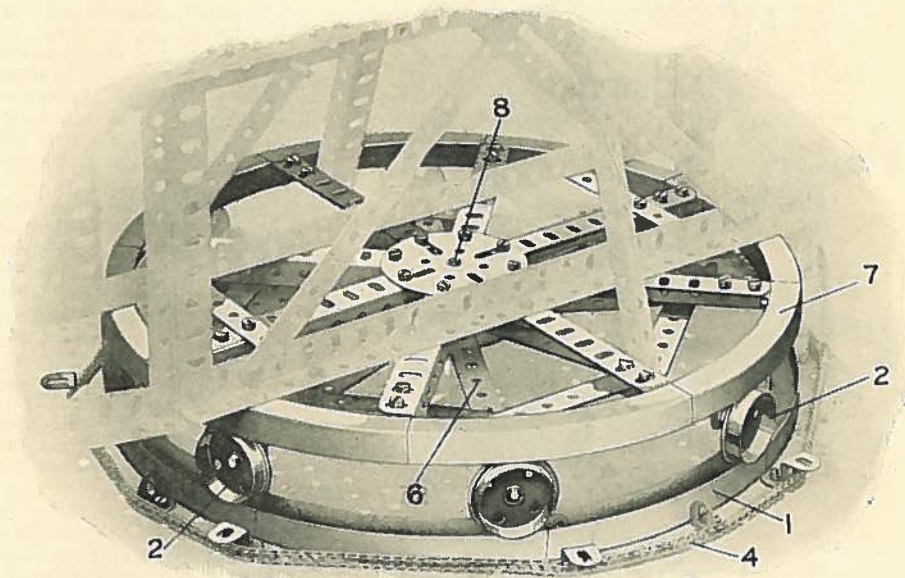

S.M. 101

figure illustrates a method of rotating the crane jib or other structure of which the track 1 forms the base; a vertical driven rod situated on the rotating structure carries a Sprocket Wheel placed *within* and engaging the chain loop 4. The latter is arranged round the series of Angle Brackets 5. On rotation of the Sprocket Wheel, the chain 4 tends to grip the brackets and becomes immovable, whereupon the Sprocket commences to travel *round the chain*, carrying the pivoted structure with it.

Eight Flanged Wheels forming the wheel race are mounted by means of  $1\frac{1}{2}''$  Double Angle Strips to the spider-frame 6 (S.M. 101B). The revolving guide rail 7, shown in detail in S.M.101c, is secured to the base of the upper or rotating part of the structure, and rests upon the wheels 2. A shaft 8 (S.M.101c) is journaled in the bearing 9 (S.M.101A) and forms a common axis for the spider-frame and revolving race 7, both of which rotate at different speeds. The shaft 8 should be secured in the Face Plate 10 forming the hub of the upper race 7, but the spider-frame 6 should be allowed to swivel freely upon it.

(Continued overleaf)

## Section VII. Roller and Ball Bearings, etc.—(continued)

### S.M. 101—Roller Bearings (continued)

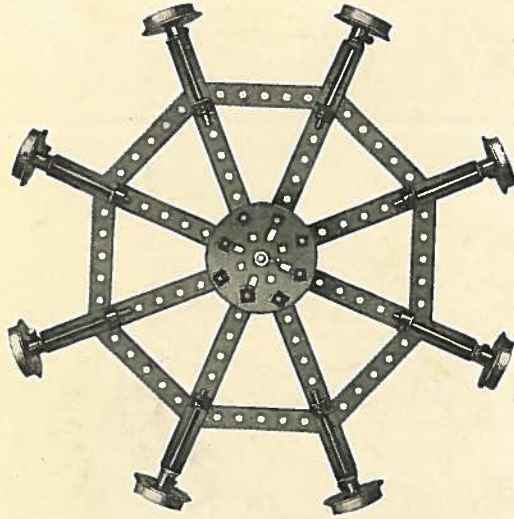

S.M. 101b

As already intimated, rollers sometimes take the place of wheels in actual practice. The rollers are of no great length but their diameters are usually made as large as possible, since an increase in size means a proportional decrease in friction. In addition, the rollers are tapered, as a rule, towards one end, in order that they shall describe a correct circle about the central pivot of the structure.

Rollers are also employed in smaller types of bearings, such as in shaft-journals, etc. Such bearings are similar in design and operation to the ordinary ball-bearings (see S.M. 104), but the advantage obtained from the employment of rollers in place of balls exists in the fact that the point of contact, or the area over which the strain is imposed, is increased considerably. Thus, in a journal-bearing, the rollers are placed longitudinally to the journal, and the latter is supported upon the entire length of each roller, whereas in ball bearings the point of contact is comparatively very small.

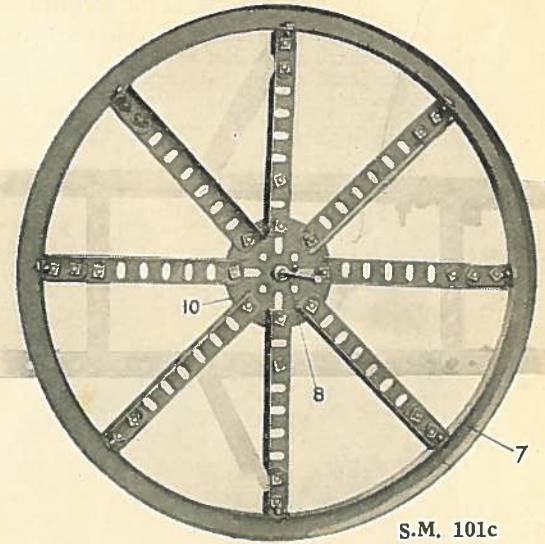

S.M. 101c

### S.M. 102—KNIFE-EDGE BEARING

The knife-edge is employed almost universally in weighing-machines, balances, etc., where it is necessary to reduce friction in a moving lever to an absolute minimum. In the Meccano movement shown in S.M. 102, the steel or agate prisms (or "knife-edges") are represented by two Centre Forks 1 secured in a Coupling 2 with their points resting between the teeth of two  $\frac{1}{4}$ " Pinions 3 bolted to a short Rod rigidly held at either end in a Crank 4. The beam 5 is secured in the centre hole of the Coupling 2, and it will be noticed that the lever arms 6 and 7 are bolted in Couplings 8 at a lower level than the Coupling 2; the beam is shaped in this way in order to lower the centre of gravity at the fulcrum 1.

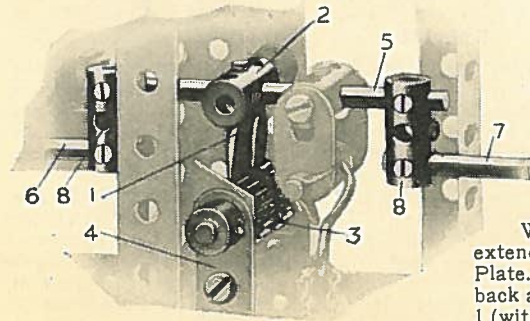

S.M. 102

### S.M. 103—REINFORCED BEARING

Where a shaft is subjected to unusual pressure it is advisable to extend, or reinforce, the ordinary bearing afforded by a Meccano Strip or Plate. S.M. 103 shows the method adopted to reinforce the bearings of the back axle of the Meccano Tractor. The axle is journalled through a  $1\frac{1}{4}$ " Pulley 1 (with set-screw removed) securely bolted to the side plate 2. The recess cut in the boss of the Pulley to receive the set-screw forms a useful receptacle for oil when lubricating the axle.

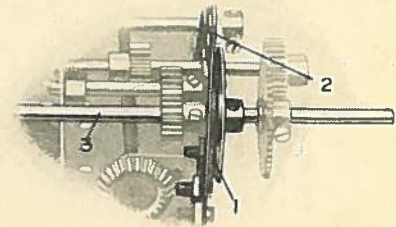

S.M. 103

## Section VII. Roller and Ball Bearings, etc.—(continued)

### S.M. 104—BALL BEARINGS

This detail illustrates the standard Meccano ball-bearing. It is constructed from two 3" Pulley Wheels, one Wheel Flange, and twenty-one Steel Balls, and is applicable chiefly in models where a weight is required to impose vertically upon a pivot. The fixed ball-race is built up from the Wheel Flange and one 3" Pulley bolted together and secured to any suitable base. The balls are placed in the groove formed between the outer edges of this Pulley and the Wheel Flange, and the second Pulley, which should be bolted to the swivelling portion of the model, rests upon their upper surfaces. One of the Pulleys is secured by its set-screw to the Axle Rod shown, while the other is allowed to turn freely. When the Pulleys are placed together, it is impossible for the balls to move out of position.

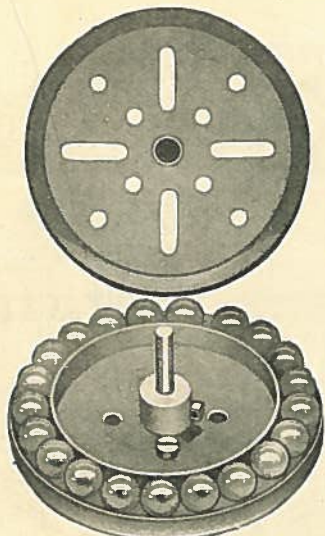

S.M. 104

### S.M. 105—BALL BEARINGS APPLIED TO SWIVELLING CRANE

S.M.105 shows the jib of a small crane running on Meccano ball bearings, such as described in S.M.104. The Rod 5, about which the jib pivots, is secured in the upper Pulley 1, which is bolted to the jib. The latter is rotated from the Crank Handle 8 by means of the Worm 7 engaging with the 57-teeth Gear Wheel 6 carried on the Rod 5. The jib is secured to the base by a Collar bolted on the Rod 5 just beneath the platform.

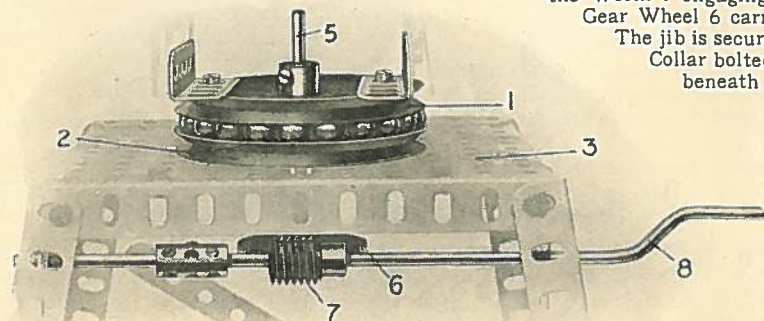

S.M. 105

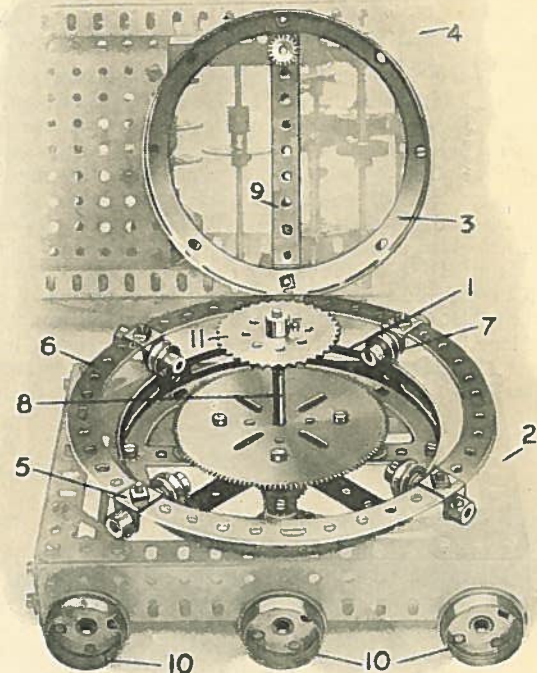

S.M. 106

### S.M. 106—ROLLER BEARINGS

The swivel-bearing shown in this illustration is similar in principle to S.M.101, but is designed for lighter work. The Hub Disc 1 is bolted to the base 2 of the model and forms a guide upon which runs the wheel-race constructed from four  $\frac{1}{4}$ " Pulleys 7, pivotly carried from a Circular Strip 6. A Circular Girder 3 bolted to the upper platform 4 of the model rests upon the Pulleys 7. The model pivots about the Rod 8, which passes through the Girder 9, but the weight of the rotating body is distributed over the Pulleys 7, so obviating the strain that would otherwise centre upon the pivot 8.

## Section VIII. STEERING-GEAR

### S.M. 115—MOTOR CHASSIS STEERING GEAR AND SPRING SUSPENSION

This is a very interesting model of automobile steering mechanism, and is shown fitted to the Meccano Motor Chassis. The steering wheel shaft, which may be situated at any convenient angle to the horizontal, rotates the Contrate Wheel on the Rod 2, by means of a  $\frac{1}{2}$ " Pinion. An alternative method of connection may be employed, consisting of a Worm Wheel engaging with a 1" Gear Wheel or Pinion mounted on the shaft 2. The latter carries a Crank 3 pivotally attached to a bolt gripped in a Collar on a further Rod 4. A Coupling bolted to the other end of this Rod 4 is pivotally connected in a similar manner to the end of the short Rod 5, the outer end of which forms the bearing for one of the road wheels. This Rod 5 is secured in a Coupling 9 mounted on a 1" Rod journalled in a Crank 10. The latter is bent slightly as shown and secured to a reinforced cross-bar 8. The further road wheel 6 is caused to imitate the turning movement of the first road wheel by means of a connecting Rod 7, which is pivotally carried from the shanks of long bolts secured in Collars on 1" Rods mounted in the Couplings 9.

The chassis springs shown in this illustration should be noted. The laminated springs 1, consisting of a series of Strips of varying sizes slightly curved, are bolted to the cross-piece 8, and are pivotly connected at their outer ends to Collars mounted on a transverse Axle Rod. Their other ends are suspended by means of a Double Bracket and short Rod from a Coupling pivoted to the chassis frame; this connection allows for lateral movement when the springs are flattened by sudden jolts, or shocks, imparted from the road wheels.

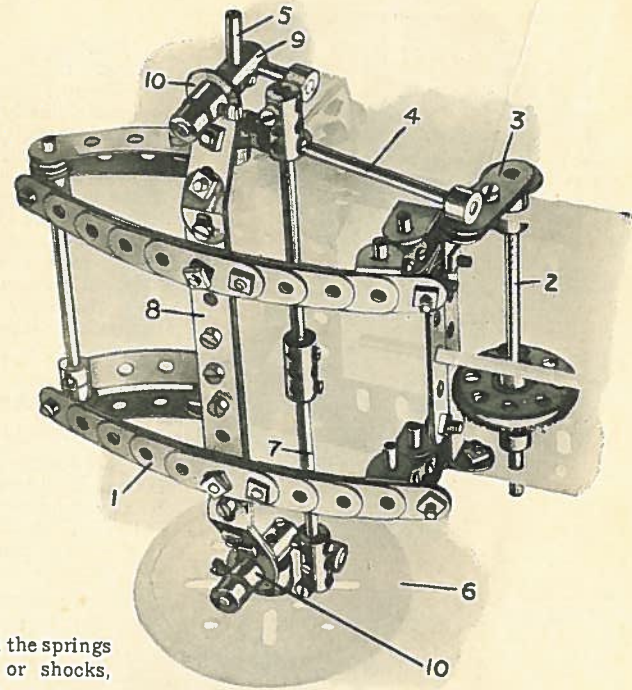

S.M. 115

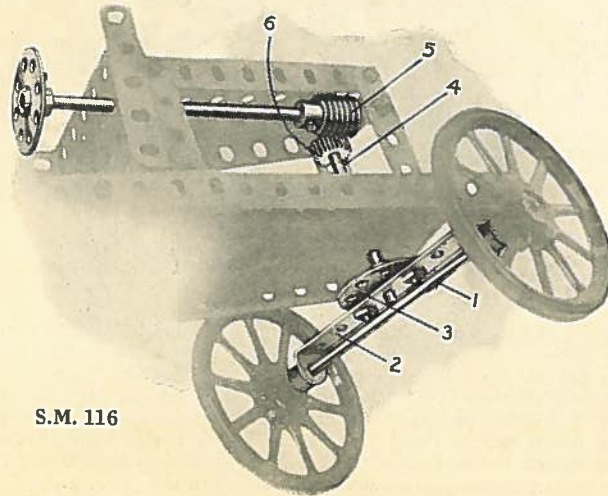

S.M. 116

### S.M. 116—WORM AND PINION STEERING GEAR

The axle 1 of the front road wheels is journalled in a  $3\frac{1}{2}$ " Double Angle Strip 2 bolted to a Bush Wheel 3. The latter is secured to a vertical shaft 4, which also carries a  $\frac{1}{2}$ " Pinion 6. On operation of the steering wheel, the shaft 4 is rotated by means of the Worm Wheel 5 engaging the Pinion 6, consequently altering the position of the road wheels as desired.

This gear will be found very useful in constructing small models of motor cars, trucks, etc. The road wheels cannot be deviated from the line in which they are set unless the steering wheel itself is turned.

## Section VIII. Steering Gear—(continued)

### S.M. 117—STEERING GEAR

The axle 2 is carried from a Double Angle Strip 1 bolted to a Bush Wheel, as in S.M. 116, but is rocked about its pivot by means of a connecting Strip 3. The latter is pivoted at 7 to the Strip 1 by means of bolt and nuts (see S.M. 262) and at the other end 6 to a Crank 4 secured to the steering shaft 5.

Double Bent Strips form extended bearings for both the steering-column, and short Rod about which the Bush Wheel and Double Angle Strip 1 pivot.

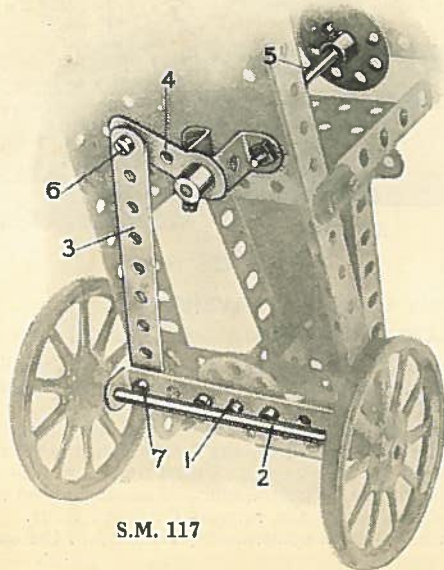

S.M. 117

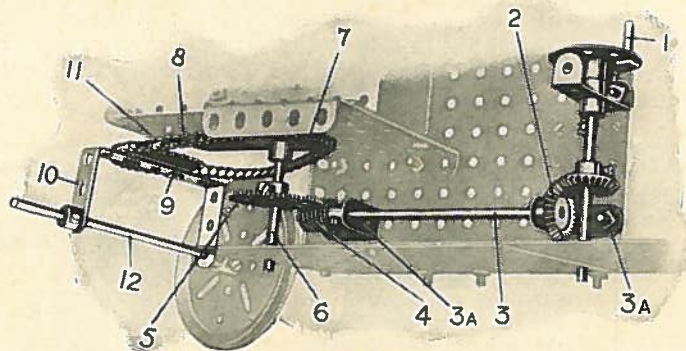

S.M. 118

### S.M. 118—STEERING GEAR FOR TRACTOR

This type of steering gear is particularly suitable for use in model road tractors, etc. The hand wheel 1 rotates by means of Bevel Gears 2 a horizontal shaft 3 journalled in 1"×1" Angle Brackets 3A. The shaft 3 carries a Worm Wheel 4 engaging with a 57-teeth Gear Wheel 5 on the vertical Rod 6. The  $1\frac{1}{2}$ " Sprocket Wheel 7 secured to this Rod engages, through a Sprocket Chain 8, a similar Sprocket Wheel 9 bolted to the Double Angle Strip 10 and carried from a short Axle Rod 11 journalled in suitable bearings in the front of the tractor. The Strip 10 forms bearings for the axle 12 of the front road wheels. Washers should be placed on the bolts between the Sprocket 9 and Strip 10, in order to allow sufficient clearance for the Chain 8.

Several alternative methods of construction may be employed. For example, the Rod 6 may be placed in a horizontal position and a short length of chain wound upon it so that, as one end is hauled in, the other is paid out. The two ends of the chain are secured to the extremities of the Double Angle Strip 10.

### S.M. 119—STEERING GEAR

The method adopted in guiding the road wheels in this model is as follows: the steering shaft 1 operates, through a Contrate gear 2, the cross Strip 3 bolted to a Crank secured to the vertical Rod 4. Cords 5 lead from the ends of this cross Strip to the ends of a Double Angle Strip 6 pivoted by bolt and nuts (S.M. 262) to the Double Bent Strip 7 and carrying the axle 8 of the road wheels.

It will be noted that the steering-shaft 1 is mounted at an obtuse angle to the Rod 4.

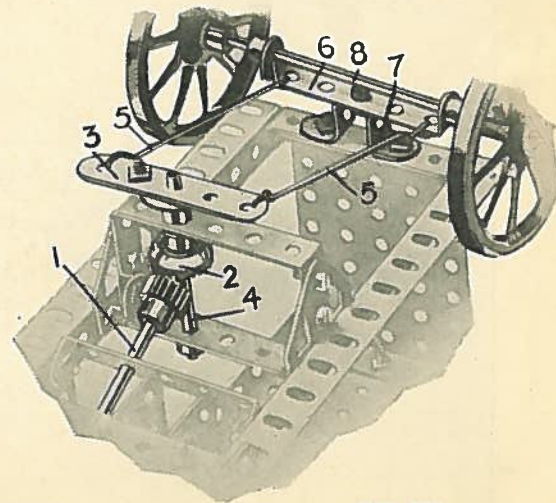

S.M. 119

## Section IX. SCREW MECHANISM

The Threaded Rod is one of the most useful features of the Meccano system ; it readily lends itself to a wide variety of ingenious movements, and, as will be seen from the examples included in this section, it enables some very important mechanical movements to be reproduced with detailed accuracy. It also proves invaluable as a method of increasing the available power, although at a considerable loss of speed, in order to cope with exceptionally heavy loads.

### S.M. 131—SCREW GEAR, OPERATING JIB OF CRANE

The Threaded Rod 1 engages the threaded borings of an Octagonal Coupling 2, which is pivotally carried from the jib 3 on short Rods 4.

The jib, in turn, is pivoted at 5 to the base 6.

The Rod 1 is secured in a Threaded Coupling 7 bolted to a short Rod 8 ; and the Bevel Wheel 9 on the latter is rotated from the operating handle 10 through 1" Gear Wheels 11 and bevel reversing gear 12 (see S.M. 66). The reverse is effected on operation of a lever 13 pivoted at 14 and bolted to a Double Bracket 15, which is carried on the shaft 16 and spaced by Washers between the two Bevel Wheels. The jib 3 is caused to rise and fall according to the direction of rotation of the Threaded Rod 1.

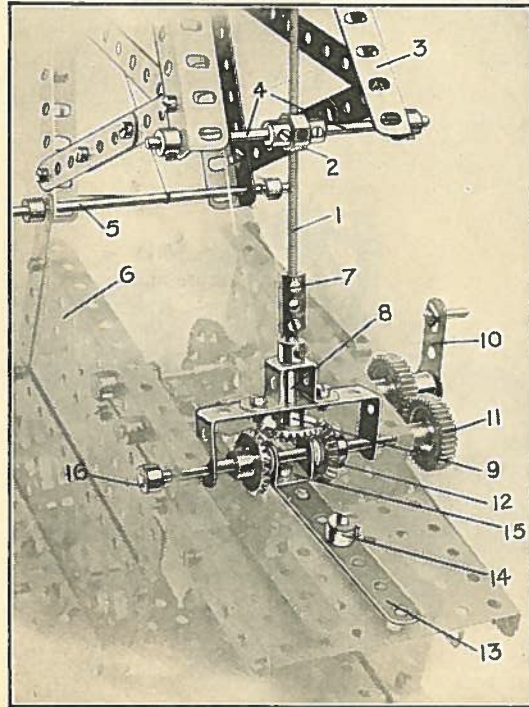

S.M. 131

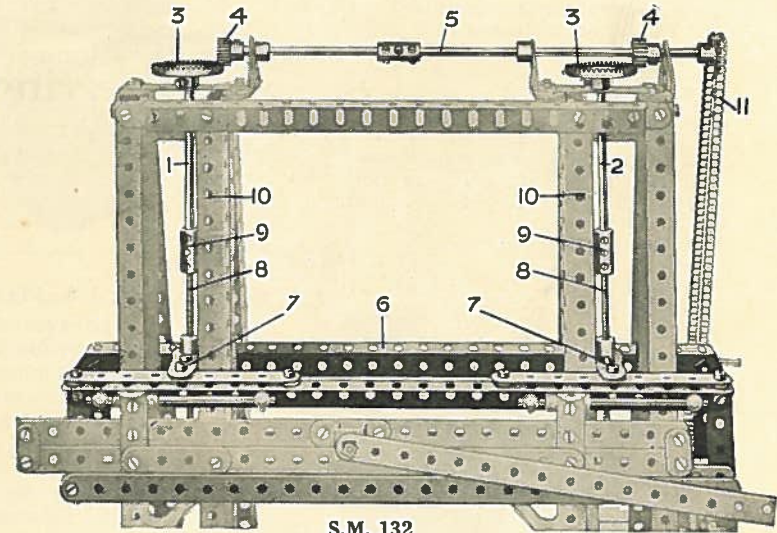

S.M. 132

### S.M. 132—APPLICATION OF SCREW GEAR IN TRAVERSING MECHANISM OF MACHINE TOOLS

This detail shows a section of the Meccano Log Saw (Model No. 624). In this model Threaded Rods have been employed to adjust the position of the saw, in order that the logs may be cut in sections of any desired thickness.

A vertically adjustable frame 6, which carries the saw, slides on the upright members 10, and is operated from the Threaded Rods 8. These engage with the Threaded Cranks 7 bolted to the frame, and are connected at their upper ends to Axle Rods 1 and 2 by Couplings 9. Rods 1 and 2 are rotated simultaneously from the horizontal shaft 5 by means of 1½" Contrate Wheels 3 and ½" Pinions 4 ; and the frame 6 is raised or lowered according to the direction of rotation of the vertical Threaded Rods.

The shaft 5 is connected by Sprocket Chain 11 to a hand-wheel conveniently situated in the base of the model.

## Section IX. Screw Mechanism—(continued)

### S.M. 133—HOISTING GEAR OF CRANE DRIVEN BY SCREW MECHANISM

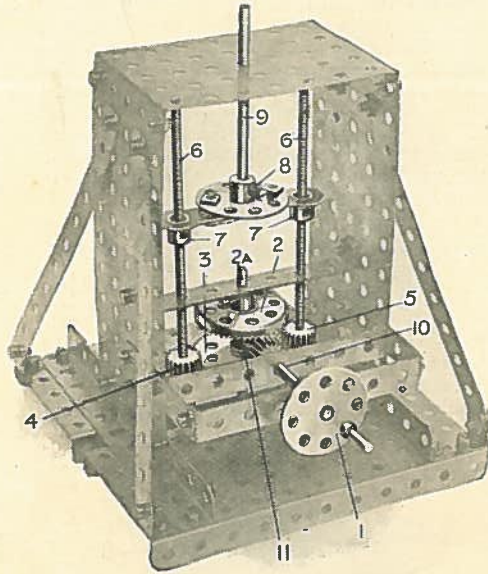

S.M. 133

The hand-wheel 1 rotates a Contrate Wheel 2, secured to a shaft 2A, carrying a 57-teeth Gear Wheel 3 which drives the  $\frac{1}{2}$ " Pinions 4 and 5 secured to the vertical Threaded Rods 6. The latter engage the bosses of two Threaded Cranks 7 bolted to a Bush Wheel 8. On operation of the hand-wheel 1 the Rod 9 is raised or lowered, and its movement is employed to draw in or pay out the hoisting cord of the crane by means of a series of Pulleys. The method by which the hoisting cord is operated is similar to that adopted in hydraulic cranes, and an excellent representation of the necessary gear will be found in Model No. 724.

It should be noted that the Rod 10 is journalled in the end of a Coupling 11 which is loosely mounted and spaced with Washers on the Rod 2A.

### S.M. 134—SCREW-OPERATED JIB-RAISING GEAR

This detail illustrates a method by which Screw Gear may be employed in elevating the jib of a heavy crane, or similar work, and incidentally forms a very fine model of the type of gear used in the majority of the world's largest cranes.

The drive is led by way of the  $1\frac{1}{2}$ " Contrate Wheel 1 and 1" Gear Wheel 2 secured to the short Rod 3, to further

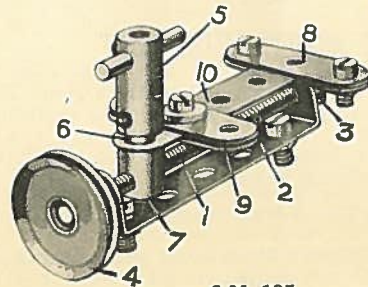

S.M. 135

### S.M. 135—LATHE TOOL ADJUSTING DEVICE

The Threaded Rod 1, journalled in a Double Angle Strip 2 and held in place by a Collar 3, is rotated by the hand-wheel 4. The tool post 5 is secured to a Threaded Pin 6, which is screwed into a Threaded Boss 7 engaging the Rod 1. Consequently rotation of the hand-wheel causes the tool post to travel to and fro. Two  $2\frac{1}{2}$ " Strips on the lathe saddle are bolted between the  $1\frac{1}{2}$ " Strips 8 and form guides on which further  $1\frac{1}{2}$ " Strips 9 are allowed to slide. The  $2\frac{1}{2}$ " Strip 10 secured to the tool post slides between the  $1\frac{1}{2}$ " Strips 8.

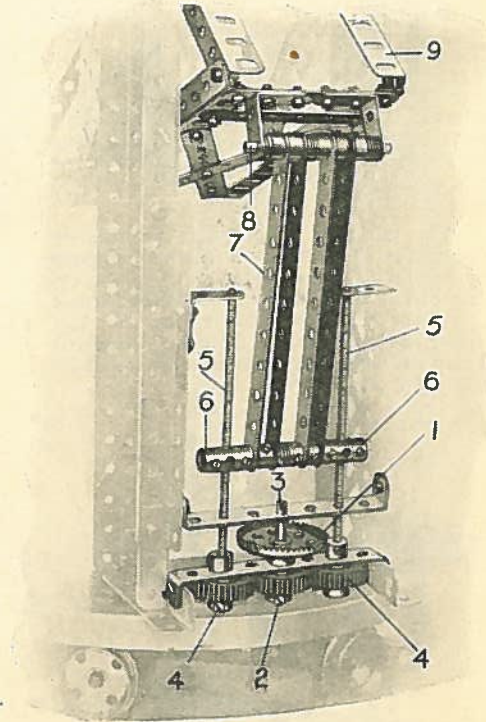

S.M. 134

Wheels 4 carried on the vertical Threaded Rods 5. The latter engage the threaded borings of two Couplings 6, and as they rotate these Couplings are forced slowly up or down. The links 7, pivotally attached at their lower ends to a Rod 8, transmit this movement to levers 9 which in turn are pivotally attached to the jib of the crane. The jib is therefore raised or lowered in consequence of the movement of the Couplings 6.



## Section IX. Screw Mechanism—(continued)

### S.M. 136—ADJUSTING AND LOCKING DEVICES

S.M. 136 shows a screw adjustment fitted to the tail-stock of a lathe. The Threaded Rod 1 engages the boss of a Threaded Crank 2, bolted to the tail-stock 3 which slides between Angle Girders 4. The tail-stock is guided by means of a Double Angle Strip, bolted to its underside, engaging the Rod 5. The Threaded Rod 1 is secured by a Coupling 6 to the Rod 7, and is rotated by a hand-wheel 8.

The tail-stock is locked in position on turning the Threaded Boss 9, which engages the shank of a bolt passed through a  $1\frac{1}{2}$ " Strip placed transversely beneath the Girders 4. As the Threaded Boss turns, the bolt presses against this  $1\frac{1}{2}$ " Strip and causes it to grip the Girders 4, so holding the tail-stock rigidly in position.

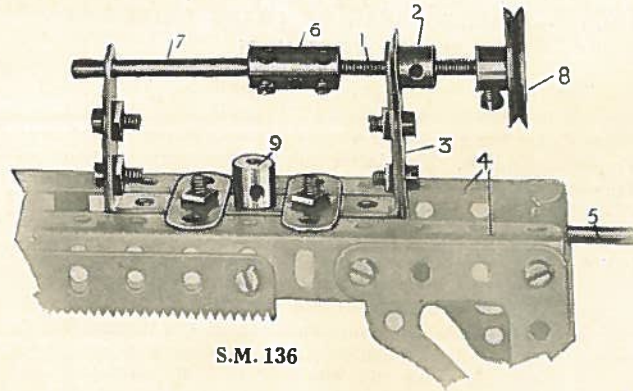

S.M. 136

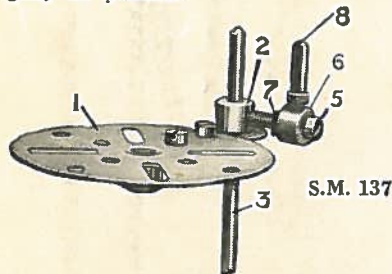

S.M. 137

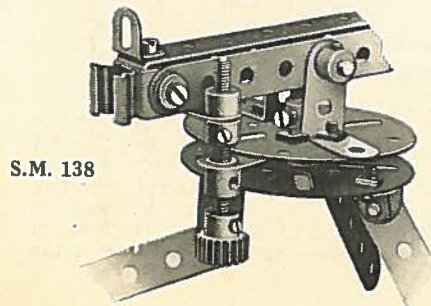

S.M. 138

### S.M. 137—LOCKING DEVICE

This illustrates a method by which the table of a drilling machine, or similar apparatus, may be quickly and rigidly locked, in any position. The table 1 is bolted to a Crank 2 sliding on a vertical shaft 3. A  $\frac{3}{4}$ " bolt 5 is inserted in the boss of the Crank, and carries a Collar 6 which is held in place on the bolt by a nut 7. The table is locked in the desired position by twisting the bolt 5 until it nips the shaft 3; a suitable handle is provided by a Threaded Pin 8 inserted in the Collar 6.

### S.M. 138—SCREW ADJUSTMENT

The Threaded Rod shown in this illustration is employed to adjust the elevation of a machine gun. The rod, engaging a Threaded Crank bolted to the swivelling base, passes through a Flat Bracket on the gun, and is held in place by two Collars. The adjustment is effected by rotating the  $\frac{1}{2}$ " Pinion shown.

### S.M. 139—SCREW ADJUSTMENT

Here the Threaded Rod is employed as a device for adjusting the table of a drilling or boring machine, etc. The table 1 is bolted to a Threaded Crank 2, the boss of which engages the vertical Threaded Rod 3. The latter carries a Pinion 5, which gears with the Worm Wheel 4 on the shaft of the hand-wheel 6.  $2\frac{1}{2}$ " Angle Girders 8 bolted to the table and connected by a Double Bracket 7 slide upon the vertical Girders 9, and form guides to hold the table in position.

The table is raised or lowered according to the direction of rotation of the hand-wheel.

Note.—Where a Threaded Rod is required to rotate in bearings, it should be first connected by Couplings to ordinary Axle Rods, if possible, so that the latter may be journalled in the bearings instead of the Threaded Rod; it will be found that this results in better and smoother working.

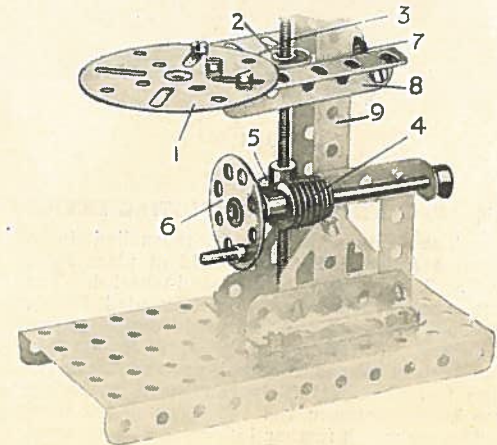

S.M. 139

Further examples of SCREW MECHANISM will be found in S.M. 85 and 86 (Section VI.)

# Section X.

## OVERHEAD TROLLEYS & TRUCKS FOR GANTRIES, ETC.

### S.M. 151—OVERHEAD TRAVELLER FOR GANTRY

The construction of the trolley is simple and will be readily followed from the illustration. Sections of the front  $2\frac{1}{2}$ " Strips 8 have been cut away in order to reveal the mechanism more clearly. The wheels 4 are arranged to run on rails, constructed from Angle Girders laid down on the gantry, while the pulley block and hoisting cord 5 are suspended between them.

The trolley is traversed on operation of the handle 1, on the shaft of which a  $\frac{1}{2}$ " Pinion 2 is mounted, and engages with the 57-teeth Gear Wheel 3; the latter is secured to the axle of one pair of running wheels 4, and so imparts motion to the trolley.

One end of the hoisting cord 5 is connected to the framework of the trolley, while the other end is led round a  $\frac{1}{2}$ " loose Pulley carried on the shank of a bolt 9 in the pulley block 10, and wound on the Crank Handle 11. The load is prevented from falling back when hoisted by means of a Pawl 6 and Ratchet Wheel 7 (see S.M. 84).

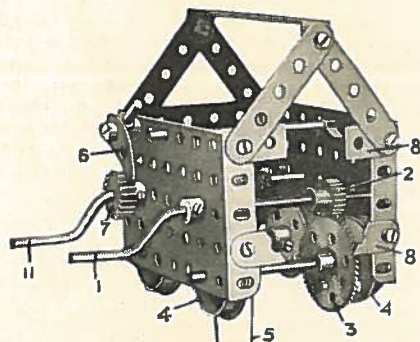

S.M. 151

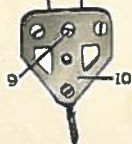

### S.M. 152—TRUCK, WITH AUTOMATIC DISCHARGE

The  $4\frac{1}{2}$ " x  $2\frac{1}{2}$ " Flat Plate 1, forming the bottom of the truck, pivots about the Rod 2, and carries a short Double Angle Strip 3, which is spaced away from the Plate by means of five Washers placed on each of the bolts 4. A short Rod 5 journalled in the strip 3 carries a  $\frac{1}{2}$ " loose Pulley 6, which runs upon a third rail laid in the centre of the track on which the Flanged Wheels 7 are guided. This centre third rail dips down the side of a chute placed beneath the truck runway, with the result that, on the truck reaching this spot, the bottom plate 1 falls open, since the Pulley 6 is no longer supported, and the contents of the truck are discharged. As the truck returns for a fresh load, the Pulley is forced up the sloping end of the centre rail, until the bottom of the truck is again closed.

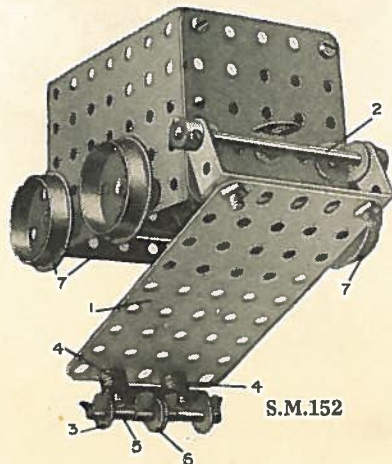

S.M.152

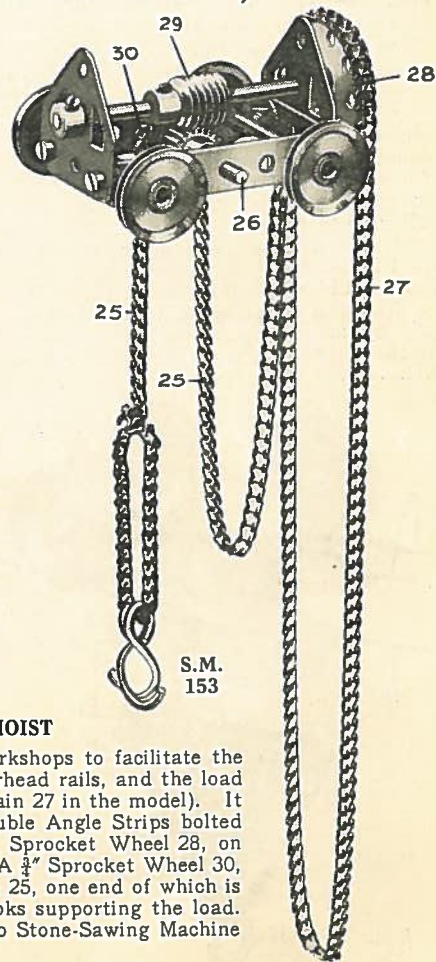

S.M.  
153

### S.M. 153—OVERHEAD TROLLEY, WITH CHAIN HOIST

S.M. 153 illustrates a device employed in many factories and workshops to facilitate the movement of heavy loads by hand power. The trolley runs upon overhead rails, and the load is raised by hauling upon an endless chain (represented by Sprocket Chain 27 in the model). It will be observed that the trolley is constructed from two  $2\frac{1}{2}$ " x  $\frac{1}{2}$ " Double Angle Strips bolted together at each end by two Flat Trunnions. The chain 27 rotates a Sprocket Wheel 28, on the shaft of which is a Worm 29 engaging a  $\frac{1}{2}$ " Pinion on the Rod 26. A  $\frac{3}{4}$ " Sprocket Wheel 30, also secured to the Rod 26, engages a further length of Sprocket Chain 25, one end of which is secured to the framework of the trolley, and the other carries the hooks supporting the load.

This Hoist is used to handle the material to be cut in the Meccano Stone-Sawing Machine (Model No. 617) and may be employed in all similar models.

# Section X. Overhead Trolleys & Trucks for Gantries, etc.—(continued)

## S.M. 154—OVERHEAD TRAVELLER FOR GANTRY

The axles 1 of the travelling wheels are journalled through the ends of four  $2\frac{1}{2}$ " Strips 2 placed together and spaced by Washers in a central position in the trolley 4. Two pairs of 2" Strips 3 are bolted to the Strips 2 and are connected at their lower ends by Curved Strips 6.  $\frac{1}{2}$ " loose Pulleys 12 on short Rods 7 form guides for the hoisting cord 9, which passes round a 1" Pulley 13 in the pulley block 8. The latter is constructed from two Triangular Plates spaced apart by Collars 10 and secured by  $\frac{3}{4}$ " Bolts 11. The Hook 14 is suspended from a 1" Axle Rod 15.

The trolley is caused to travel along the rails by means of the cord 5, both ends of which are secured to the framework 4 (see S.M. 169).

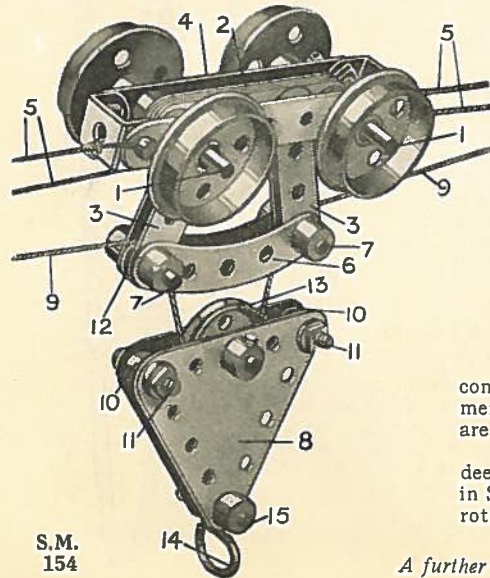

S.M.  
154

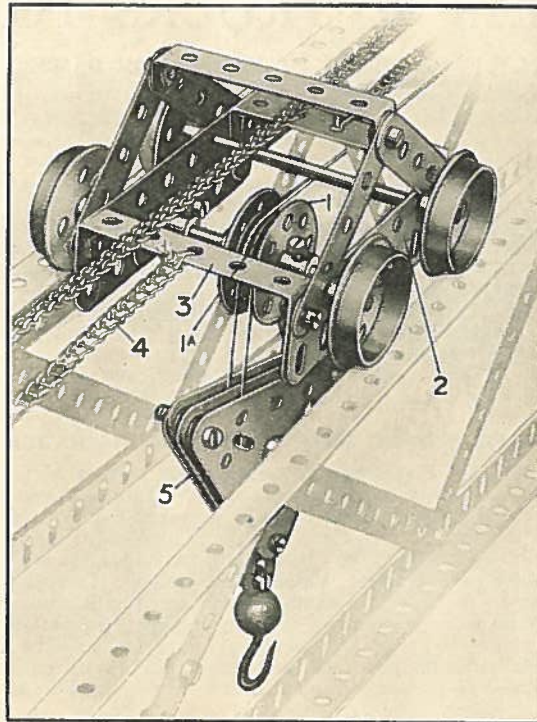

## S.M. 155—OVERHEAD TRAVELLER FOR GANTRY, AND TWO-SHEAVED DEEP GROOVED PULLEY

The wheel-base 2 is constructed from two  $3\frac{1}{2}$ " Flat Girders connected by  $2\frac{1}{2}$ "  $\times$  1" Double Angle Strips 3. The traversing movement is imparted by means of a Sprocket Chain 4, the ends of which are connected to the Bent Strips 3 (see S.M. 169).

A feature of this trolley is the two-sheaved pulley 1 with specially deep grooves. This is built up in a similar manner to that described in S.M. 39, but in this case the 1" loose Pulleys 1A should be free to rotate at different speeds between the Bush Wheels.

The pulley block 5 is described in S.M. 32 (Section III.)

A further example of Overhead Trolley mechanism is shown in S.M. 68 (Section V.)

## S.M. 156—OVERHEAD TRAVELLER FOR GANTRY

The trolley in this illustration is constructed from two  $3\frac{1}{2}$ " Strips 1 connected by  $1\frac{1}{2}$ "  $\times$   $\frac{1}{2}$ " Double Angle Strips 2. The axles 3 and 3A of the running wheels carry two  $2\frac{1}{2}$ " Strips 9 held between Collars and set-screws 10. The hoisting cord 6 is led over a  $\frac{1}{2}$ " loose Pulley 5, situated between the  $2\frac{1}{2}$ " Strips 9 on the axle 3A, and passes round a second  $\frac{1}{2}$ " Pulley carried on the shank of the bolt 11 in the pulley block 7; from thence it passes over a further  $\frac{1}{2}$ " Pulley 5A on the axle 3.

The traversing movement of the trolley is obtained from the cord 8, the ends of which are shown connected to the cross Strips 2.

The pulley block 7 is built up from two Flat Trunnions bolted together, Washers being placed between the Trunnions on the shanks of the bolts 12.

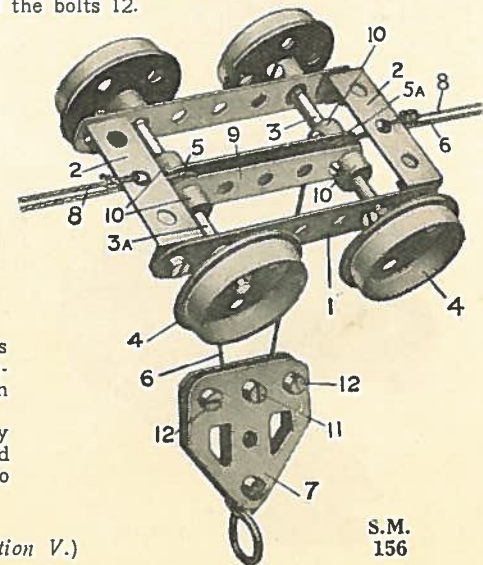

S.M.  
156

# Section XI. TRAVERSING MECHANISM

## S.M. 165—TRAVERSING MECHANISM OF HEAVY DRAGLINE

S.M. 165 is an underneath view of the base of a heavy Dragline, and illustrates a type of traversing mechanism in which the driving power is coupled to sixteen travelling wheels running on a quadruple track.

The drive is led by way of a vertical shaft and Bevel Gears 6 and 7 on to the transverse  $11\frac{1}{2}$ " Rod 5, and two  $\frac{1}{2}$ " Pinions 4 on either end of this Rod 5 actuate further  $\frac{1}{2}$ " Pinions 3, each of which is mounted separately on a short Rod. Four  $\frac{3}{4}$ " Sprocket Wheels 2 secured to the shafts of the Pinions 3 are each connected by Sprocket Chain 1 to 1" Sprocket Wheels mounted on short Rods 8 journaled in the centre of the bogies 9. The eight wheel axles are all rotated in the same direction by means of  $\frac{3}{4}$ " Pinions 10 gearing with 50-teeth Gear Wheels 11.

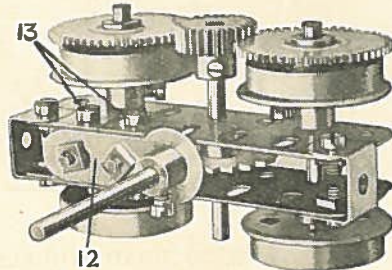

S.M. 165a

One of the four-wheeled bogies is shown in detail in S.M. 165A; the Crank 12, seen in this illustration, is bolted to two Double Brackets 13, and forms a socket to receive the upright columns 14, which are bolted to each corner of the base.

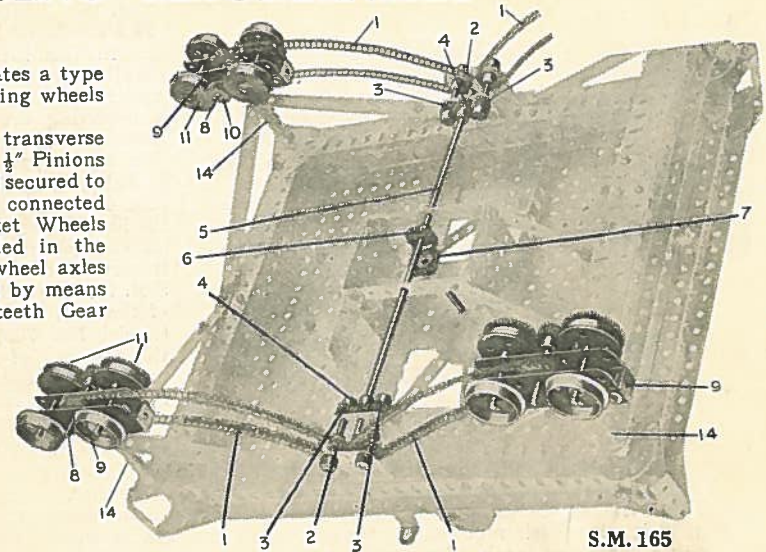

S.M. 165

## S.M. 166—RACK AND PINION TRAVERSING MECHANISM

Rack and Pinion gear possesses a wide range of utility. In actual practice it is employed for an innumerable variety of purposes, ranging from the operation of a steep mountain railway to the simple gear sometimes used in opening a row of factory windows.

S.M. 166 shows Rack and Pinion gear adapted to actuate the saddle of a lathe. The saddle 1 rests upon the Girders 2, and is bolted to a  $2\frac{1}{2}$ " x  $\frac{1}{2}$ " Double Angle Strip sliding upon a Rod set longitudinally between the Girders. The shaft 3 of the hand-wheel 4, journaled in strips 5 bolted to the saddle, carries a  $\frac{1}{2}$ " Pinion which engages the Rack Strips 6. As the hand-wheel rotates, the Pinion is forced along the Rack, carrying the saddle with it.

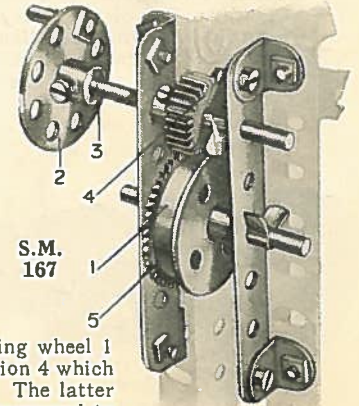

S.M. 167

## S.M. 167—TRAVERSING MECHANISM

This illustrates the foot of a crane or similar model, in which the travelling wheel 1 is operated from a hand-wheel 2. The shaft 3 of the hand-wheel carries a  $\frac{1}{2}$ " Pinion 4 which engages a 50-teeth Gear Wheel 5 secured to the axle of the Flange Wheel 1. The latter is one of four wheels similarly situated in the base of the model, and all are arranged to traverse a suitable stretch of track.

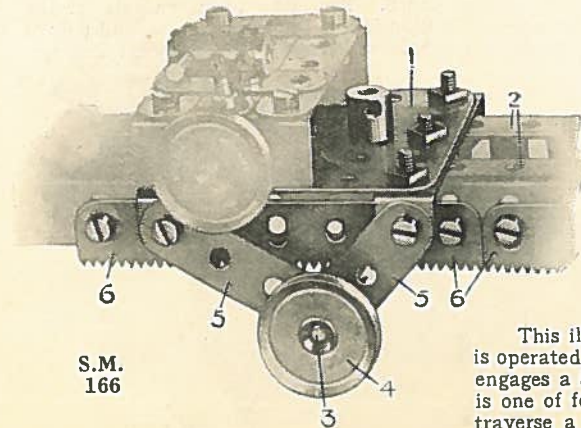

S.M. 166

## Section XI. Traversing Mechanism—(continued)

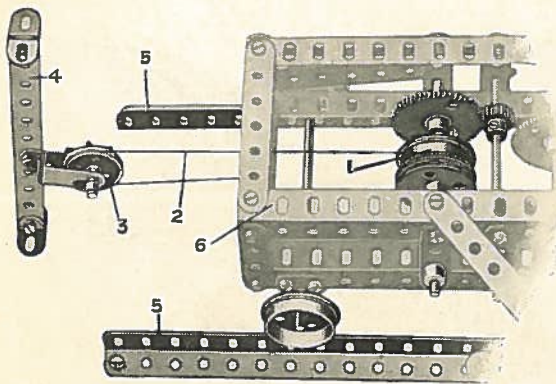

S.M. 168

### S.M. 168—SELF-HAULED TRAVELLING CARRIAGE

In this interesting apparatus the moving machine *pulls* itself along, by means of a revolving drum 1 which slowly winds up a cord 2. The latter passes round a 1" Pulley 3, carried from the post 4 secured in position at the head of the track 5, and its end is attached to the framework of the carriage 6. S.M. 168 illustrates a section of the Coal-Cutting Machine (Model No. 703), in which this type of traversing mechanism is employed in moving the cutting tools slowly along the coal face as the coal is cut away.

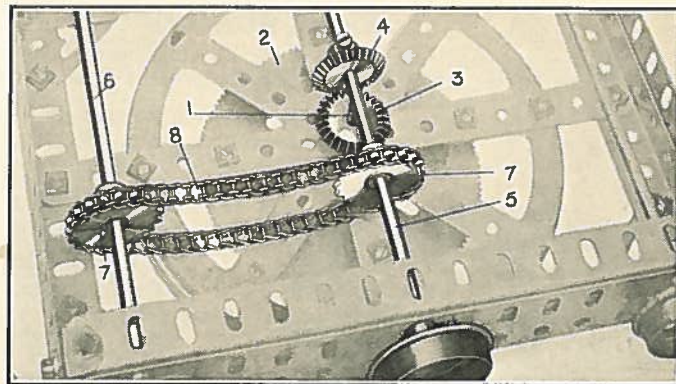

S.M. 170

### S.M. 170—TRANSMISSION OF MOTIVE POWER TO ROAD WHEELS

S.M. 170 is an underneath view of the wheel-base of the Steam Shovel (Model No. 707). In this model the Motor is carried in the swivelling superstructure and the drive is led down to the road wheels by way of the vertical shaft 1. This shaft is journaled through the boss of the  $3\frac{1}{2}$ " Gear Wheel 2, about which the superstructure pivots, and carries a Bevel Wheel 3 gearing with a similar wheel 4 on the transverse Rod 5. The latter forms an axle for the centre pair of the six road wheels. Motion is also imparted to a second pair of wheels on the axle 6 by means of 1" Sprocket Wheels 7 and Sprocket Chain 8.

**S.M. 169—ENDLESS ROPE TRAVERSING GEAR**  
This movement may be employed in overhead cranes, gantries, endless-rope railways, transporters, conveyors, etc., and numerous other models where it is required to move a trolley or truck to and fro along a stretch of track. Its construction consists of an endless cord secured to the trolley and passing round a pulley at either end of the runway. One of the pulleys imparts the motive power, and the cord should be given an additional turn round this pulley to obtain sufficient "grip." Sprocket Chain may be used in place of the cord, when a more powerful and reliable drive will be obtained.

### S.M. 171—RECIPROCATING MOTION

Where a part of a machine is required to reciprocate over a comparatively short distance, the necessary traversing movement may be imparted by ordinary crank and connecting-rod gear. In S.M. 171 a Threaded Pin 1, secured to the Bush Wheel 2, pivotly carries a connecting Strip 3, which imparts to and fro movement to a carriage sliding on guide Rods 4.

*Further examples of Reciprocating Drive mechanisms are given in S.M. Nos. 252 and 264 (Section XI11.)*

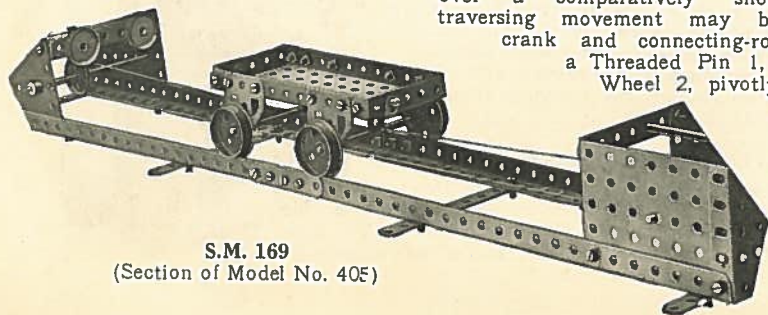

S.M. 169  
(Section of Model No. 405)

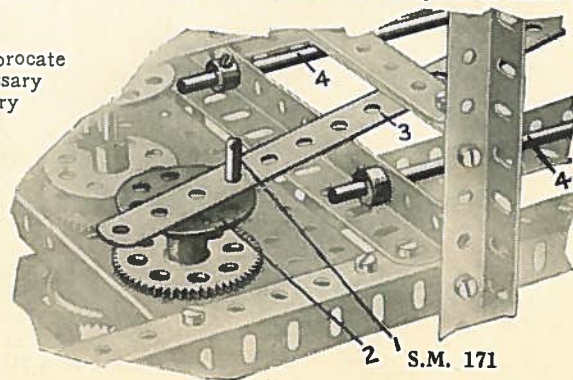

S.M. 171

# Section XII. GRABS, BUCKETS and DREDGING APPARATUS

## S.M. 181—SHOVEL FOR GIANT EXCAVATOR

This bucket is designed for use in Steam Shovels or other excavating machines. It is bolted to the arm 1, which pivots from a point in the jib of the excavator. The bottom Plate 2 of the bucket is hinged to the Rod 3, and is closed or opened as desired by means of a sliding Rod 4, operated by a cord 5. Thus, during the cutting stroke, the Plate 2 is held in a closed position by the end of the Rod 4 engaging a Flat Bracket 6. When the loaded bucket is moved over to the point where the material is to be dumped, its contents are released by pulling the cord 5. The bucket is raised or lowered by a cord 7 engaging a Pulley 8 pivotly carried on a Rod 9. The radius of the cut is regulated by altering the length of the arm 1, which is controlled by rack and pinion mechanism in the jib.

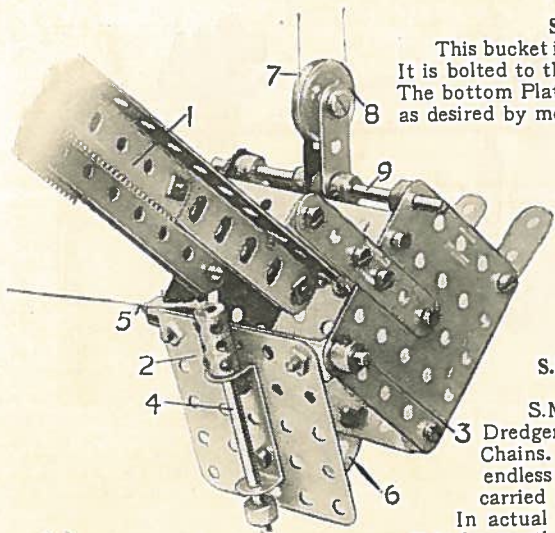

S.M. 181

## S.M. 182—BUCKET DREDGING APPARATUS, or BUCKET CONVEYOR

S.M. 182 clearly shows the method by which Meccano Dredger Buckets (Part No. 131) may be secured to Sprocket Chains. Any number of buckets 1 may be connected to the endless chain 2, which passes round a Sprocket Wheel 3 carried in the end of the dredger arm.

In actual practice this mechanism is used for other work in addition to dredging; it is frequently employed, for example, in elevators and conveyors for coal slack, gravel, cement, and for loading similar materials in wagons, etc.

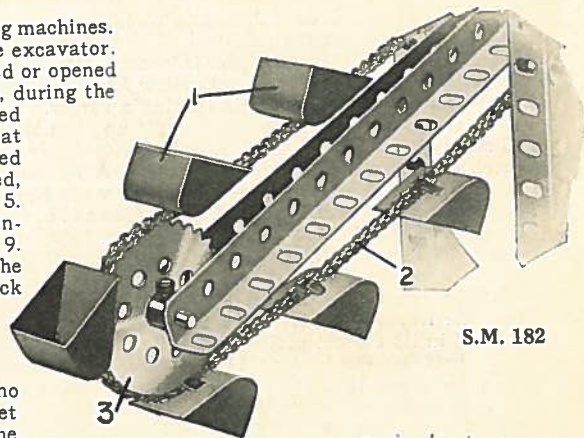

S.M. 182

## S.M. 183—BUCKET FOR DRAGLINE EXCAVATOR

The construction of the bucket will be followed from the illustration. On the cutting stroke, the teeth 1 are drawn into the earth by means of the Chain 2, while a cord 3 sustains the bucket at the requisite angle. The apparatus is raised or lowered by means of the pulley block 4.

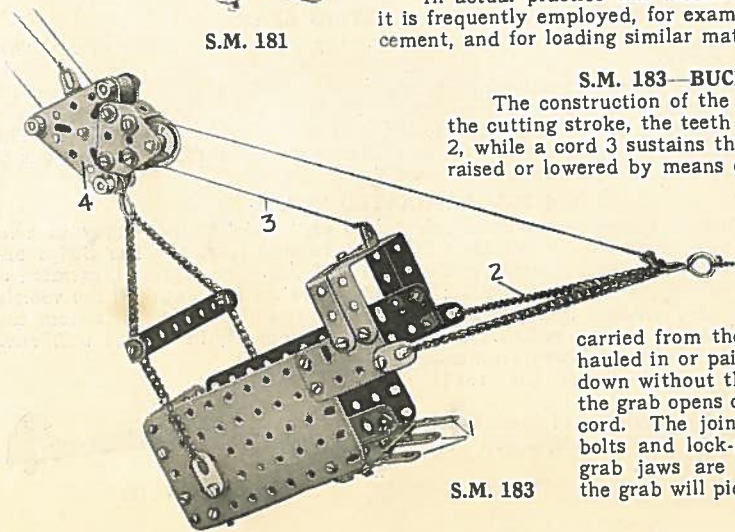

S.M. 183

## S.M. 184—GRAB

The grab jaws are constructed from 2½" Triangular Plates 1 extended at their bases by 2½" Curved Strips 2. The grab is raised or lowered by means of four lengths of cord 3, while another cord 4 passes round a 1" Pulley carried from the cross-piece 5. If both the cords 3 and 4 are hauled in or paid out at the same speed, the grab travels up or down without the jaws moving, but if one cord ceases to move, the grab opens or closes according to the movement of the other cord. The joints marked "A" are all pivoted by means of bolts and lock-nuts (see S.M. 263). If the outer sides of the grab jaws are filled in with cardboard, or additional parts, the grab will pick up small loads of sand, marbles, etc.

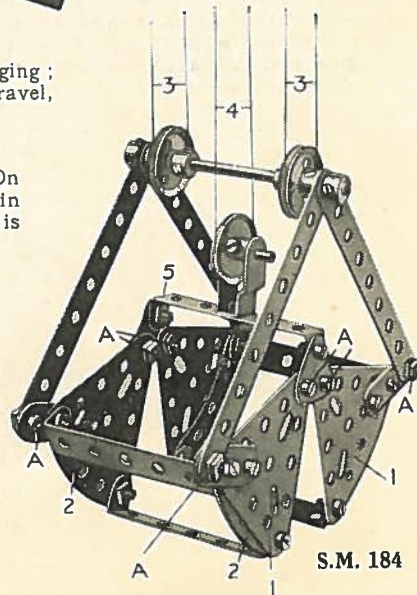

S.M. 184

## Section XIII. MISCELLANEOUS APPLIANCES

### S.M. 251—DIFFERENTIAL GEAR

The Differential Gear shown in S.M. 251 is undoubtedly one of the most interesting examples of the practical value of the Meccano system. As all Meccano boys are aware, differential gear is incorporated in the drive transmission on every motor-car; the object of this is to allow for the difference in the speed of the outer road wheel when the vehicle is turning a corner.

In the model, the back axle is built up from two separate units—a  $3\frac{1}{2}$ " Rod 1 and a  $5\frac{1}{2}$ " Rod 2—which abut in and revolve freely in the Coupling 3. A Contrate Wheel, 4 and 5, is secured to each unit. A  $1\frac{1}{2}$ " Contrate Wheel 6, with set screw removed, is allowed to revolve freely upon the Rod 2, and is driven from the  $\frac{1}{2}$ " Pinion 7 on the propeller shaft 8. The frame 9, consisting of two  $1\frac{1}{2}$ " Double Angle Strips, revolves with the Contrate Wheel 6, to which it is secured by 1" Threaded Rods 10. Two  $\frac{3}{4}$ " Pinions 11 and 12 are mounted on 1" Rods 13, for which the centre transverse hole of the Coupling 3 forms a bearing; they are thus free to revolve independently of each other, but they are engaged by the Contrates 4 and 5. The outer frame 14 consists of a  $3\frac{1}{2}$ "  $\times$   $1\frac{1}{2}$ " Double Angle Strip, and the inner frame 9 is held in its correct position by a Collar 15 and Washers 16. Washers may be placed between the Pinions 11 and 12 and the Coupling 3 if required, and care should be taken that the inner frame 9 revolves freely upon the axles 1 and 2.

It will now be seen that if one road wheel revolves at a greater speed than the other, the Pinions 11 and 12 begin to rotate, and adjust the difference in speed between the Contrate Wheels 4 and 5. If the vehicle is running in a perfectly straight course, however, the axles 1 and 2, Contrates 4 and 5, and Pinions 11 and 12, must all rotate as one unit, since the road-wheels are travelling at the same speed.

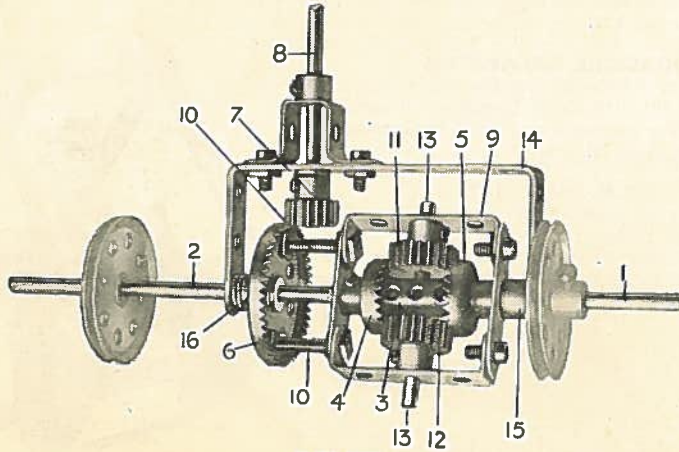

S.M. 251

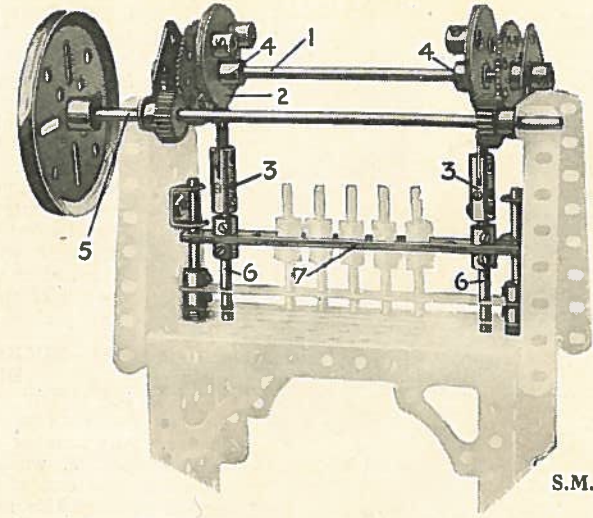

S.M. 252

### S.M. 252—RECIPROCATING GEAR

The Meccano Eccentric provides a stroke, or throw, of three different dimensions, namely,  $\frac{1}{2}$ ",  $\frac{3}{4}$ ", and 1", and it forms a valuable method by which any continuous movement may be converted to reciprocating motion. S.M. 252 shows two Eccentrics operating the tools of a punching machine. The Rod 1 is journaled through the Eccentric boss 4, providing  $\frac{1}{2}$ " throws, and is driven from the main shaft 5. The Eccentrics 2 are pivotly connected to Strip Couplings 3 mounted on guide Rods 6, which carry the punches from a cross piece 7.

### S.M. 253—LAMINATED SPRING

Laminated springs—sometimes referred to as "leaf" springs—may be constructed from a number of Meccano Strips of varying lengths. The Strips are slightly bent and bolted together as shown in S.M. 253. The spring illustrated is designed for use in a motor chassis; it is bolted to the framework of the vehicle by means of the Angle Brackets shown, and supports the road wheels from the Double Bracket at the end. A similar spring frequently in use has both ends bolted to the vehicle, whilst its centre rests upon the axle of the road wheels.

A further example of laminated springs for chassis suspension is shown in S.M. 115.



S.M. 253

# Section XIII. Miscellaneous Appliances—(continued)

## S.M. 254—VARIABLE SPEED : THE CONSTANTINESCO TORQUE CONVERTER

The Torque Converter—as this ingenious apparatus has become generally known—was invented recently by Mr. George Constantinesco. Briefly stated, it is an automatic infinitely-variable speed mechanism, which obviates the use of gear wheels and other forms of transmission that have been previously considered indispensable. Furthermore, it obtains the maximum efficiency from the engine to which it is fitted, since it transmits the power almost directly to the resistance which is to be overcome.

The ordinary rules of static mechanics do not apply to the Torque Converter, and it is only by the consideration of the elements "time" and "mass" that the behaviour of the converter can be explained, and for a complete understanding of its working, mathematics of a high order are required. We do not propose, therefore, to enter into detailed technical explanations, but merely to describe a Meccano model which admirably fulfils the purpose of demonstrating the remarkable principle on which the Constantinesco Converter is based.

An explanatory diagram of the model is given in Fig. 1. The crank A driven by the engine, is connected to a lever B, to the lower end of which is fixed a heavy weight C forming a pendulum. The other end of the lever B is connected to two rods D, E carrying pawls F, G which bear on a ratchet wheel J. No matter whether the rods D, E be pushed towards the ratchet or pulled away from it, a turning motion, constant in direction, is imparted by the pawls to the rod K.

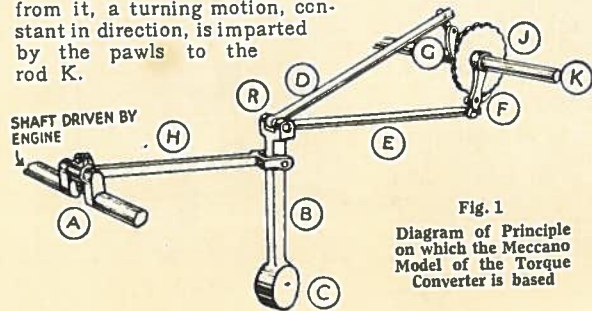
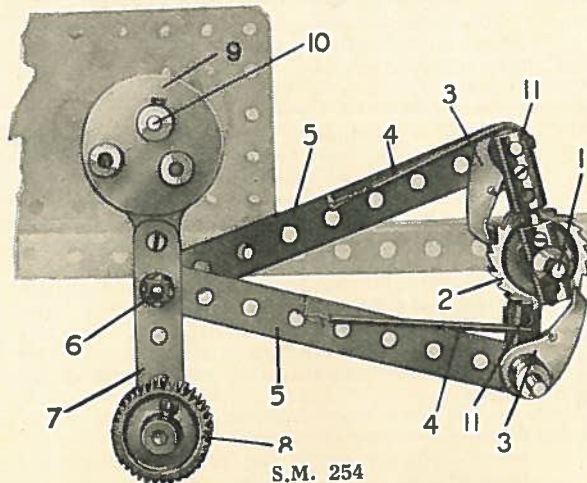

Fig. 1  
Diagram of Principle on which the Meccano Model of the Torque Converter is based



### HOW THE CONVERTER WORKS

When the engine is running slowly, the weighted lever B, actuated by the connecting-link H, swings to and fro, the fulcrum of oscillation being at the point of resistance (R). As the speed of the engine increases, however, the increased oscillatory movement of the lever B overcomes the resistance and the fulcrum automatically moves down to some intermediary point between R and C, resulting in a short to-and-fro motion of the levers D, E which imparts a moderate rotary motion to the rod K. If the engine is allowed to reach "top" speed a very rapid oscillatory motion is applied to the lever B; the inertia of the weight C opposes this motion and the weight becomes stationary, whilst the end R of the lever is rocked to the full extent of the throw of the crankshaft. The fulcrum is now right down in the weight C, and the levers D, E are caused to move almost as if they were driven directly from the engine.

The speed at which the engine must revolve before the inertia of the weight C completely overcomes the resistance at R, varies, of course, with the extent of the resistance on the rod K.

### THE MECCANO MODEL

In the Meccano model, S.M. 254, the lever B is represented by a short Strip 7 bolted to the Eccentric 9. The latter is mounted on the driving shaft 10 and imparts the oscillatory movement to the lever 7. A 1" Gear Wheel 8 represents the weight C. Two 4½" Strips 5 are pivoted by bolt and lock-nuts 6 to the lever 7, their other ends being connected to short Rods mounted in Couplings 11 and carrying the Pawls 3. The Couplings 11 are secured by 1" Rods to further Couplings which are free to move about the Rod 1. The Pawls are opposed to one another, and engage a Ratchet Wheel 2 mounted on the driven shaft 1; portions of Spring Cord 4 exert a slight pressure on the Pawls, to ensure their proper engagement with the Ratchet Wheel. Each Pawl engages with the Ratchet Wheel intermittently, one rotating it during the forward stroke of the levers 5, while the other is brought into operation on the reverse stroke. The combined effort of both produces a constant rotary motion in the shaft 1.

S.M. 254A is an end perspective of the Pawl and Ratchet gear.

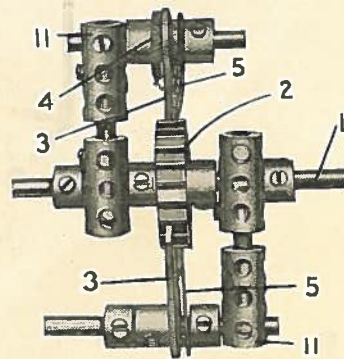

S.M. 254a



## Section XIII. Miscellaneous Appliances—(continued)

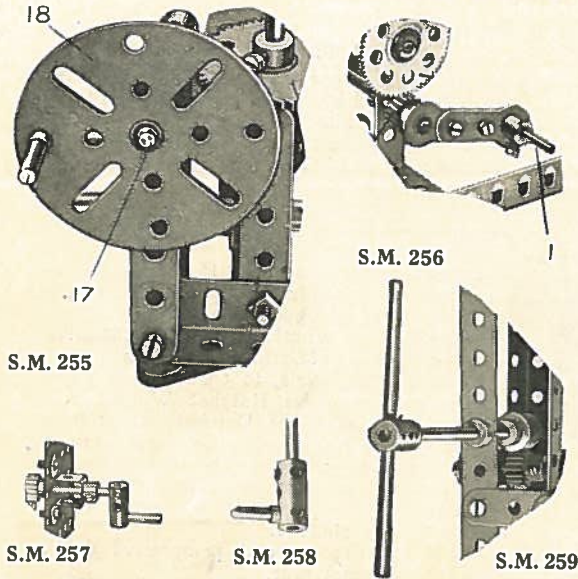

S.M. 255

S.M. 256

S.M. 257

S.M. 258

S.M. 259

### EXAMPLES OF MECCANO HANDLES, etc.

S.M. 255—Hand-wheel, constructed from a Face Plate 18, rotating about the shaft 17, and carrying a Threaded Pin.  
S.M. 256—Crank Handle, composed of two Cranks bolted together, and short Rod 1.

S.M. 257—Crank handle, formed from a Coupling and short Rod.

S.M. 258—Hand lever. The Threaded Pin engages one of the screwed borings in the end of the Coupling.

S.M. 259—Double hand lever, consisting of a transverse Rod mounted in a Coupling.

Further examples are also shown in S.M. Nos. 5, 61, 63, 67, 72, 86, 137, etc.

### S.M. 260—PEDESTAL

This detail illustrates an interesting adaptation of Meccano Couplings and Rods to form a firm base, or pedestal, for a vertical column, etc.

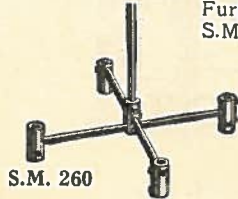

S.M. 260

### S.M. 261—QUICK-RETURN MOTION

A quick-return gear adapted in actual practice to machine tools, etc., forms a valuable means of speeding-up production. When fitted to a planing-machine, for example, as in S.M. 261, this gear so controls the drive that the table carrying the material to be shaped moves slowly during the cutting stroke, but on the return movement, during which the cutting tool performs no work on the material, the table travels much faster.

A vertical driven shaft 5 carries a Bush Wheel 6 to which an Eye Piece 7 is pivoted by means of bolt and lock nuts (S.M. 263). A  $3\frac{1}{2}$ " Strip 3 passed through the Eye Piece pivots about an upright fixed Rod 4, and is attached at its outer end 2 by pivot bolt and nuts to a connecting lever 1. The latter, in turn, is pivotally connected to the underside of the table, which slides on the girders 8.

The Bush Wheel 6 rotates in an anti-clockwise direction, rocking the lever 3 to and fro, and the swivel-guide 7 slides on the lever as it follows the movement of the Bush Wheel. Consequently the guide 7 is at a greater distance from the fulcrum of the lever during the forward stroke than it is on the return, with the result that the point 2 moves slowly on the forward stroke and more rapidly on the return.

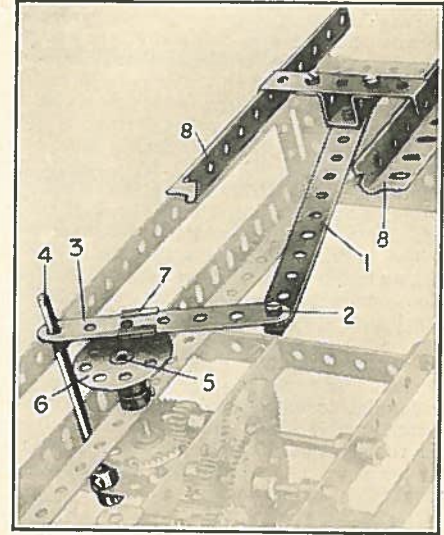

S.M. 261

### S.M. 262—PIVOT, FORMED FROM BOLT AND NUTS

A simple type of pivot, or swivel-bearing, which proves extremely useful in Meccano models, is shown in S.M. 262. The bolt 1 passes through the Strip 2 and is securely held to Strip 3 by means of two nuts 4 and 5, which are screwed tight against opposite sides of the Strip. Sufficient space is left between the nut 5 and the bolt head to allow free movement of the Strip 2.

### S.M. 263—BOLT AND LOCK-NUTS

Another form of pivot, or swivel-joint, may be constructed by first placing the Strips 2 and 3 (see illustration S.M. 262) on the bolt 1 and locking the nuts 4 and 5 on its shank. The nuts are turned in opposite directions until they securely grip each other in position on the bolt. This arrangement allows for free movement of both Strips 2 and 3, independently of the bolt.

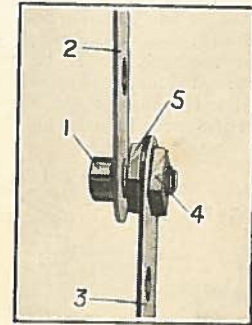

S.M. 262

## Section XIII. Miscellaneous Appliances—(continued)

### S.M. 264—CAM, OR TAPPET

For converting a regular rotary motion into a reciprocating or intermittent motion. Two Bush Wheels 1 are mounted on a vertical rotating shaft and carry a short Rod 2 which pushes a lever 3 to and fro. The lever is held against the Rod 2 by means of a piece of elastic 4 (or Spring Cord). A suitable stop may be placed in position to prevent the lever following the Rod 2 through the full distance as the latter retreats; in this way intermittent motion will be produced, for at certain periods the lever will become stationary, until the Rod 2 is again in position to push it outwards.

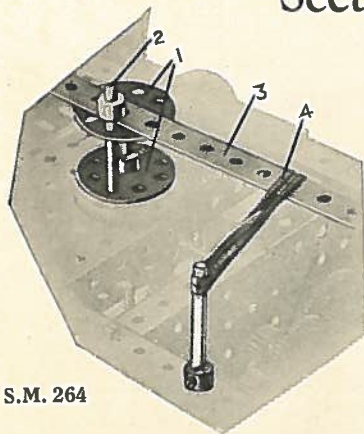

S.M. 264

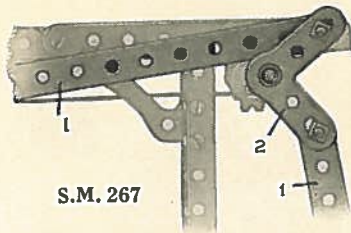

S.M. 267

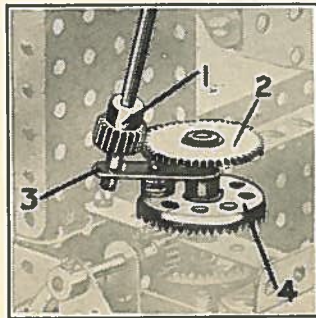

S.M. 268

### S.M. 265—INTERMITTENT ROTARY MOTION

A Centre Fork, carried in a Coupling secured to a revolving shaft, engages for a brief period in each revolution with the teeth of a 2" Sprocket Wheel secured to a second shaft, so imparting to the latter an intermittent rotary movement. This device is useful in revolution indicators, measuring instruments, etc.

Intermittent rotary motion may also be obtained with single PAWL and RATCHET gear, in which the apparatus is similar to that described in S.M. 254.

### S.M. 266—CAM, OR TAPPET

This resembles S.M. 264 and converts a regular rotary motion into a reciprocating or intermittent motion. It consists of two  $1\frac{1}{2}$ " Pulley Wheels 1, or Bush Wheels, carrying three Double Brackets 2 and secured to a revolving shaft 3. As the cam rotates, the Brackets 2 raise or lower a lever resting transversely upon the Rod 3.

The ECCENTRIC is a form of cam (see S.M. 252).

### S.M. 267—BELL CRANK

The bell crank is a lever of the first order (see Section IV. page 11) and is employed as a means of increasing or changing the direction of a force. In S.M. 267, the levers 1 are set at right-angles to each other, and one imparts motion to the other through the Bell Crank 2 (Part No. 128), to which the levers are pivotally connected by bolts and nuts (see S.M. 262).

### S.M. 268—EPICYCLOIDAL GEAR

In epicycloidal gear one toothed wheel is caused to rotate about the circumference of another. The Pinion 1 in this detail engages with the Gear Wheel 2, and is carried on a shaft journalled in a  $1\frac{1}{4}$ " Strip 3 bolted to a Contrate Wheel 4, which rotates freely upon the vertical Rod. The latter may be secured in position, so preventing the Gear Wheel 2 from turning, or it may be rotated at a different speed—or in an opposite direction—to the Contrate Wheel 4. The number of revolutions described by the Pinion 1 always exceeds that of the Contrate 4, but the speed ratio varies according to the sizes of the Pinion and Gear Wheel 2, and to the movement (if any) of the latter.

### S.M. 269—MEASUREMENT OF ANGLES

The Meccano Protractor (Part No. 135) consists of a sheet of superfine Esparto board on which are printed graduated circular and semi-circular scales. These may be cut out and affixed to models in which it is desired to measure angles, degrees, etc. S.M. 269 shows the semi-circular scale 1 and the circular scale 2 attached to the sighting arm and fixed base respectively of a theodolite. Note the "plumb-line"—the Coupling 3 suspended by cord 4—by which the perpendicular is ascertained.

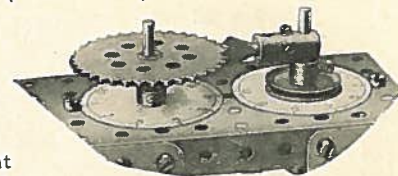

S.M. 265

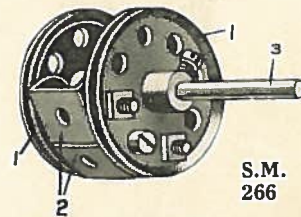

S.M. 266

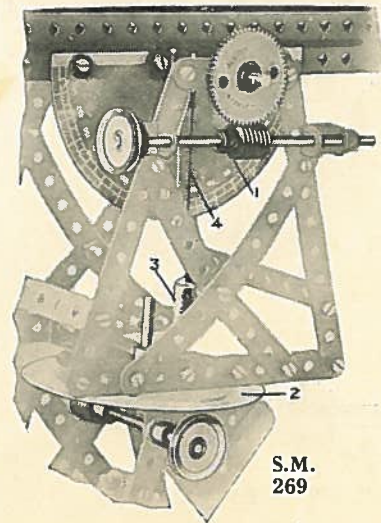

S.M. 269

## Section XIII. Miscellaneous Appliances—(continued)

### VARIABLE AND MULTIPLE DRIVING MECHANISM

#### S.M. 270—VARIABLE ROTARY DRIVE

S.M. 270 illustrates a method by which the length of a driven shaft may be varied while it is in motion. The detail shows the gear adapted to a drilling machine. It will be noticed that the vertical drill shaft is in two segments, the upper driven segment 10 being connected to the lower by means of a Bush Wheel 1 engaging two short Rods 2 mounted in another Bush Wheel 3, which is secured to the lower segment 4. The drilling tool carried on the latter is applied to the work on pressing a lever 5, and on release is returned to its former position by the compression spring 7, which is mounted on the shaft 4 between a Collar 6 and the Double Angle Strip forming the bearing 8. A suitable spring for the purpose is supplied in the Meccano Spring Buffer (Part No. 120A); the spring should be slightly stretched before being used in this apparatus. It will be noticed that the short Rods 2 adjust themselves to the movement of the drill by sliding in the holes of the Bush Wheel 1, with the result that the lower segment 4 remains in gear with the driven shaft 10 throughout its vertical movement.

S.M. 270A is another view of the drill-adjusting device. The lever 1 is pivotally mounted at 3 by means of bolt and lock-nuts (S.M. 263) and engages with the Eye Piece 2. The latter is connected—also by bolt and lock-nuts—to a Double Bracket 9 (S.M. 270) mounted on the drill shaft 4.

#### S.M. 271—MULTIPLE-DRIVE MECHANISM

This mechanism is frequently employed in multiple drilling machines and similar apparatus where a number of shafts are required to rotate at a uniform speed and in the same direction. A vertical Rod 5 carries a  $1\frac{1}{2}$ " Contrate Wheel 7, which is driven by the  $\frac{1}{2}$ " Pinion 8 secured to the belt pulley shaft. The Rod 5 is journaled through the bosses of two Face Plates 1 and 2, bolted to the upright column of the machine, and carries a 57-teeth Gear Wheel 4. The latter drives  $\frac{1}{2}$ " Pinions 3 secured to the four counter-shafts 6, which carry the tools mounted in Couplings on their lower ends.

#### S.M. 272—UNIVERSAL JOINT

The Meccano Universal Coupling, or universal joint (part No. 140) is designed to connect two rotating shafts lying in different planes, or meeting at a varying angle. An example of the universal joint is found in all motor cars, where it forms a flexible connection between the propeller shaft and the main driving shaft from the engine, so allowing for such vertical movement of the back axle as may be set up by the roughness of the ground, etc., over which the car travels.

#### S.M. 273—SPEED INDICATOR

An efficient instrument for measuring the speed of any rotating shaft may be constructed on the "centrifugal governor" principle (see S.M. 87), by employing the movement of the weights to actuate a pointer moving over a graduated scale (see Model No. 439, Manual of Instructions).

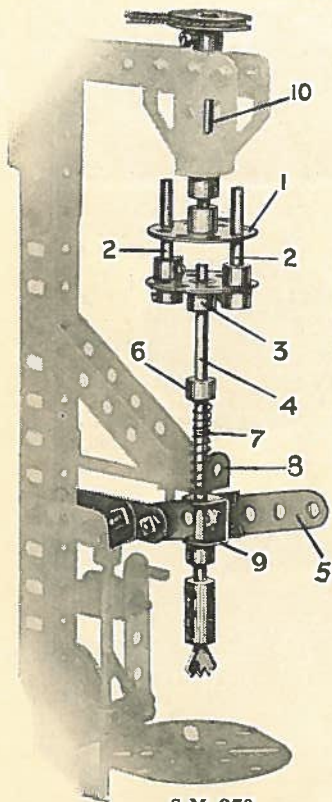

S.M. 270



S.M. 272

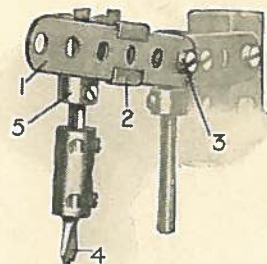

S.M. 270a

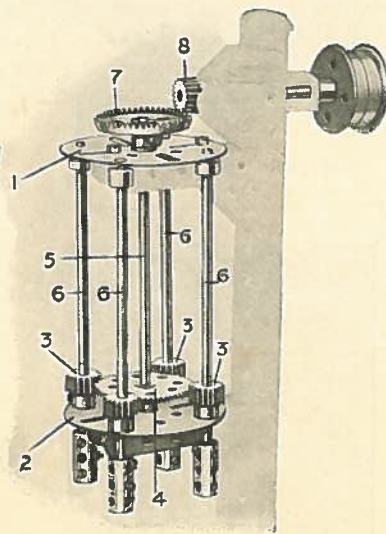

S.M. 271

# Section XIII. Miscellaneous Appliances —(continued)

## RECIPROCATING ENGINE MECHANISM

### S.M. 274—BUILT-UP CRANKSHAFT

This is a typical Meccano crankshaft, complete with balanced cranks, eccentric, etc.

The end bearing for the crankshaft 1 is formed by a Trunnion 2, Collars 3 being secured to the shaft on either side of the bearing. The crank arms are built up from Cranks 5 and 5A bolted to opposite sides of a  $2\frac{1}{2}$ " Triangular Plate 4, which forms a balance weight. The crank-pin 8 is secured in the bosses of the inner Cranks 5A, and carries the Coupling 9 secured to the connecting-rod 6. A Handrail Support 10 screws into the Coupling 9, but is spaced by Washers 11 in order that its bolt shall not grip the crank-pin. The Handrail Support is removed to admit oil through the Coupling to the crank-pin when lubricating the model.

The Eccentric 7 operates the valve mechanism, its arm being extended by a Strip 12, while the Sprocket Chain 13 rotates the engine governor (see S.M. 87).

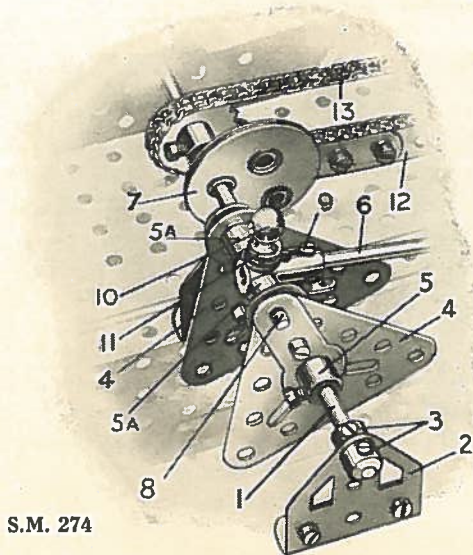

S.M. 274

### S.M. 275—CROSSHEAD

The crosshead is composed of a short Rod 6 loosely mounted in Eye Pieces 4 and held in place by Collars 7. A Fork Piece 5, mounted on the end of the piston rod 1, engages the transverse Rod 6, whilst on the latter is secured a Coupling 8 carrying the connecting rod 2. Washers should be placed on either side of the Coupling 8 to retain it in the correct position in the centre of the Fork Piece.

The Eye Pieces 4 engage the slide-bars 3 ( $3\frac{1}{2}$ " Strips) mounted in position in the base of the engine. The slide-bars, piston, and connecting-rod bearings should be oiled occasionally, to ensure smooth running, and care should be taken in mounting the connecting-rod in correct line with the piston.

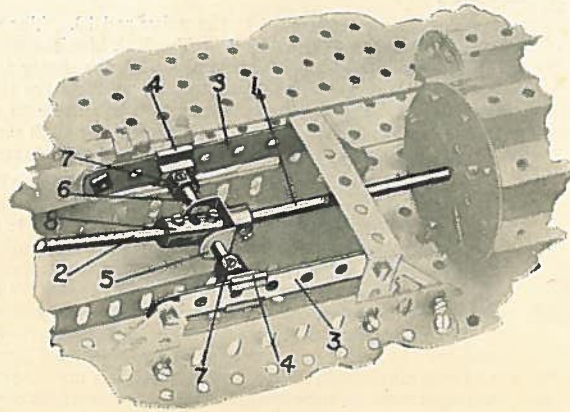

S.M. 275

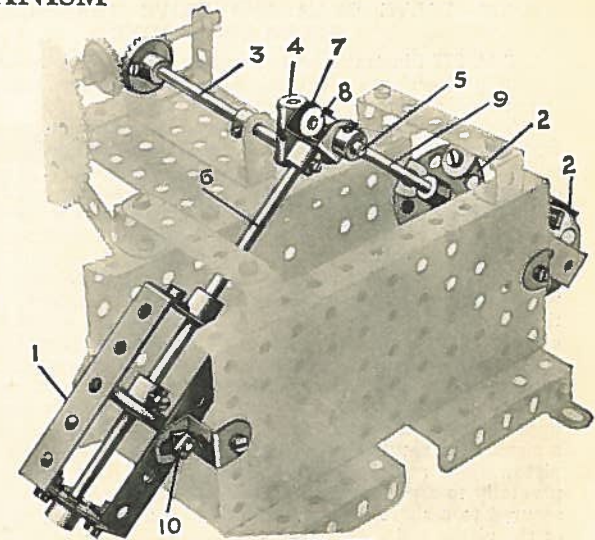

S.M. 276

### S.M. 276—OSCILLATING CYLINDERS

Two oscillating cylinders, such as are found in small steam engines or pumps, may be connected to a single crank in the manner shown in S.M. 276.

The cylinders 1 and 2 are pivoted at their centres by means of bolts and lock-nuts 10 (see S.M. 263) and the piston rods 6 and 9 are journaled on the crank pin 5. The latter is secured in the end of a Coupling 4 mounted on the crankshaft 3. The piston rod 6 is pivoted to the crank pin by means of the Fork Piece 7, whilst the piston 9 carries a Coupling 8, through the transverse hole of which the crank pin is journaled. Washers should be placed between the Coupling 8 and the sides of the Fork Pieces.

As the crankshaft rotates, the cylinders rock about their bearings. It will be noted that with this arrangement connecting-rods and crossheads are dispensed with.

## Section XIII. Miscellaneous Appliances—(continued)

### S.M. 277—VALVE GEAR AND DRIVE TRANSMISSION FOR STEAM LOCOMOTIVE

S.M. 277 illustrates an interesting model of Walschaert's valve gear and also shows a typical Meccano connecting-rod gear which is applicable to most types of locomotives.

The crosshead 1 is composed of a Coupling mounted between Eye Pieces engaging slide bars 2. A Strip Coupling mounted on the end of the piston rod 3 carries the connecting rod 4 pivoted to the crank pin on the centre driving wheel 5. The coupling rod 6 is also journalled on this crank pin and on the crank pins of the leading and trailing driving wheels, thus imparting the motion of the piston over the three wheels.

The crank pins consist of short Rods passed through the driving wheels and secured in Cranks bolted to their inner sides. A Crank 7 rigidly secured to the pin of the centre driving wheel 5, pivotally carries the return crank rod 8, and the latter is pivoted to the outer end of a short Slotted Strip forming the base of the link 9, which is constructed from 2½" Curved Strips. The link rocks about a pivot 10 and pushes to and fro the radius rod 11, which is pivoted to the upper hole of the combining lever 12. This lever 12 is journalled on a short Rod secured in a Coupling 13 mounted on the end of the piston valve rod sliding in the valve chest 13A, and is connected pivotally to a guiding link 14. The latter is pivoted to a Crank 15 secured to a short Rod mounted in the Strip Coupling on the end of the piston rod.

It will now be seen that, as the wheel 5 rotates, the combining lever 12, operated by the radius rod 11 and guiding link 14, imparts a sliding movement to the valve rod 13. The radius rod 11 is pivoted at 16, by means of bolt and lock-nuts, to an Eye Piece, representing the link block, sliding on the strip 9A of the link 9. The link block is connected to a lever in the cab, so that the driver may move it to any position in the link that he may desire. By moving the block 16 towards the pivot 10, the throw of the radius rod 11 is diminished, until it reaches its minimum when the block 16 is at the centre of the link 9. Further movement of the block to any point above the pivot 10 reverses the direction of the valve rod 13, and consequently reverses the order in which the cylinder valves open, so causing the locomotive to run in an opposite direction. The alteration to the throw of the radius rod also enables the driver to vary the amount of steam which is supplied to the cylinder for each stroke of the piston, for the inlet valve is held open for a short or long period according to the extent of the "throw" of the radius rod. This variation of the steam supply is known as the "cut-off."

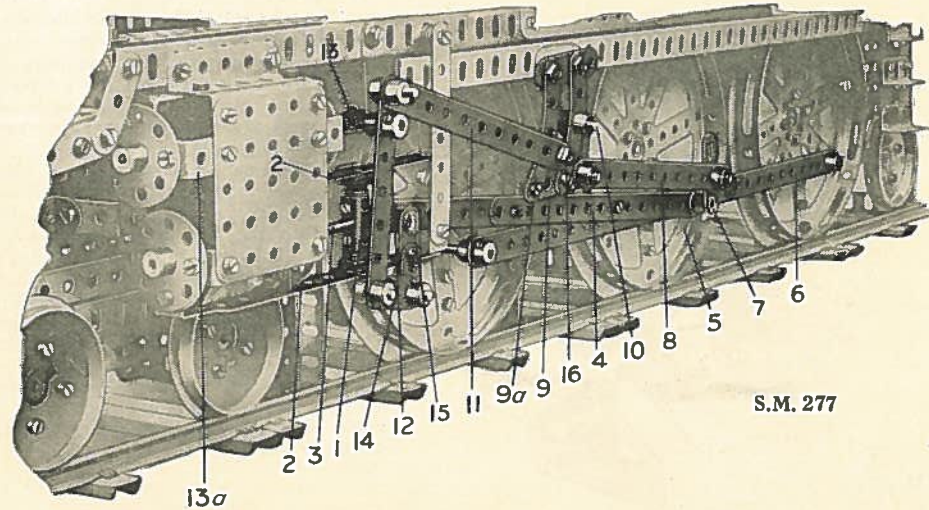

S.M. 277

### S.M. 278—AUTOMATIC BRAKE OR REVERSE DEVICE

This gear may be employed to automatically operate a brake or reversing gear in Meccano models that are required to travel upon rails. A Rod 1, passed through the rails 2, carries a Crank 3 and Coupling 4, which engages with a small projecting lever beneath the model, so operating the reversing or brake mechanisms. The web of the Crank carries a nut, bolt and Washer 5 as additional weight. The apparatus is designed to effect only models travelling in the direction of the arrow shown in the illustration. A model moving in the contrary direction strikes the Coupling 4 on the opposite side, and the Coupling, falling into a horizontal position, allows the model to pass unaffected, and is then returned to its former position by the weighted Crank 3. If a lever of this type is mounted at either end of a single length of track, a Meccano model or Hornby Loco may be allowed to travel to and fro without outside supervision or aid, or fear of its over-reaching the ends of the track. The Cranks, or balance arms of the two levers should be set, of course, in opposite positions.

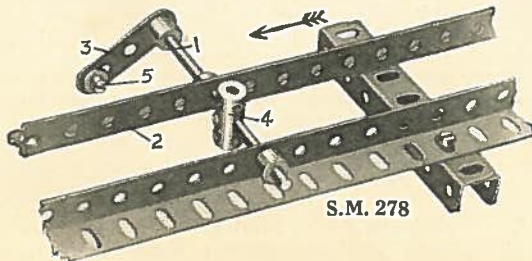

S.M. 278

## Section XIII. Miscellaneous Appliances—(continued)

### S.M. 279—WINDING GEAR FOR CRANES OR DERRICKS

The shaft of the winding handle 1, carrying a  $\frac{1}{2}$ " Pinion 2, is engaged at one end by a  $3\frac{1}{2}$ " Strip 4. The latter is bolted to the framework at 5 and is bent out a little to allow a Collar and Washer to be placed on the winding shaft between it and the frame of the gear-box. The Strip 4 thus serves as a spring which tends to retain the operating shaft in such a position that the Pinion 2 is out of engagement with the Gear Wheel 3 on the winding drum shaft. Consequently in order to rotate the drum the hand wheel 1 must be pressed inward while it is rotated; immediately it is released the Strip 4 returns it to its former position, throwing the Pinion 2 out of gear with the Gear Wheel 3.

On the other end of the drum 6 is mounted a Flanged Wheel 7 and Bush Wheel 8. These form a small drum about which the brake band 9 is wound. One end of the latter is tied to a Flat Bracket mounted on a Rod 10, whilst the other end is given a few turns round the Rod, and is secured to a bolt inserted in a Collar. On operation of a crank 11, the Rod 10 winds up the cord 9, so exerting a braking effect on the winding drum. A Ratchet Wheel 12 is secured to the shaft of the latter and is engaged by a Pawl 13. The necessary pressure is imparted to the Pawl by a piece of Spring Cord 14. The cord 15 secured to the Pawl is guided over a 1" loose Pulley 17, which revolves independently on the Rod 10 and is connected to a weighted lever 16. Normally the lever 16 rests against a stop 19; this allows the Pawl to engage the Ratchet Wheel 12. If the arm 16 is thrown over, however, its weight raises the Pawl clear of the teeth of the Ratchet and so leaves the winding drum free to revolve. This arrangement is useful when it is required to allow a load to run down by its own weight. A piece of cord 18 serves to anchor the weighted lever to the frame of the gear box.

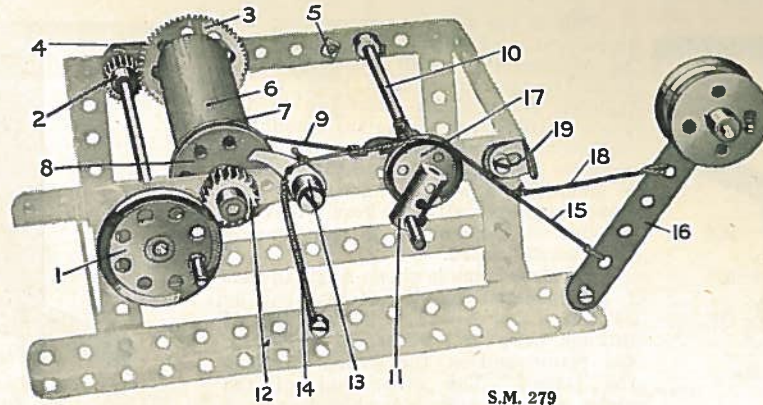

S.M. 279

### S.M. 281—SUN AND PLANET MECHANISM

"Sun and planet" gear is used to convert the reciprocating motion of a piston into motion of rotation. The Strip 1 represents the connecting-rod, imparting reciprocating motion from the piston. This Strip is bolted to a 57-teeth Gear Wheel 2, which is free to move about a Pivot Bolt 3 secured to a 2" Strip 4. The Strip 1 should be spaced away from the Gear Wheel 2 by means of a Washer placed on each of the two bolts shown, in order that the Strip may clear the second Gear Wheel 5 when in motion, whilst another Washer should be placed on the Pivot Bolt 3 immediately behind the boss of the wheel 2. One end of the 2" Strip 4 is placed upon, and is free to revolve about, the driven shaft. (The Strip is spaced away from the Gear Wheel 5 by means of three Washers).

The Gear Wheel 2 does not revolve on its own centre but moves round the axis of the gear 5 with a slightly oscillating motion, and since the teeth of both wheels are in engagement, a rotary movement is imparted to the gear 5. The latter revolves twice on its axis to one circuit of gear 2, or two strokes of the piston.

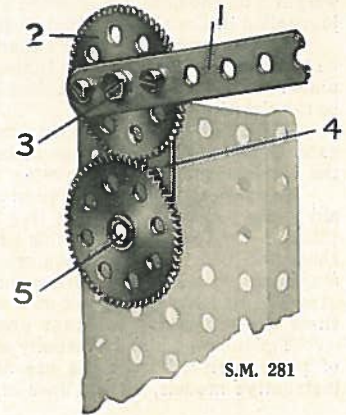

S.M. 281

### S.M. 280—DEVICE TO INCREASE LENGTH OF A CRANK STROKE

S.M. 280 illustrates a form of rack and pinion mechanism with which the length of a crank or piston stroke may be doubled. The connecting- or piston-rod is placed on the end of a  $\frac{1}{2}$ " Bolt 2, which passes through an Eye Piece 3 and carries on its shank a  $\frac{1}{4}$ " Pinion 4. The latter rolls on a Rack Strip 5 secured by Angle Brackets to the base of the model. A second Rack Strip 6 bolted to two Eye Pieces 7 sliding on a  $5\frac{1}{2}$ " Strip 8 also engages with the Pinion 4. At each stroke of the arm 1 the Pinion 4 is caused to rotate, owing to its engagement with the Rack Strip 5, and thereby thrusts the upper Rack Strip in the same direction as that in which the arm 1 is moving, but through a distance twice as great. The Strip 8 is bolted at each end to  $1\frac{1}{2}$ " Strips secured to the base by means of 1" Angle Brackets. A second guide Strip 9, secured at either end to a  $1" \times \frac{1}{2}"$  Angle Bracket, supports the Eye Piece 3.

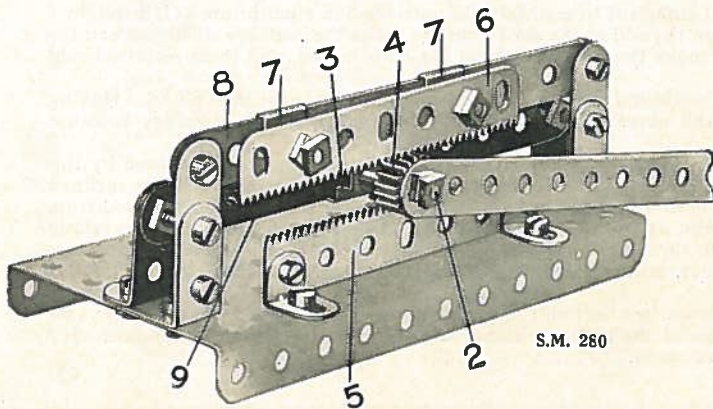

S.M. 280

# An Experiment in Applied Mechanics

## THE INCLINED PLANE

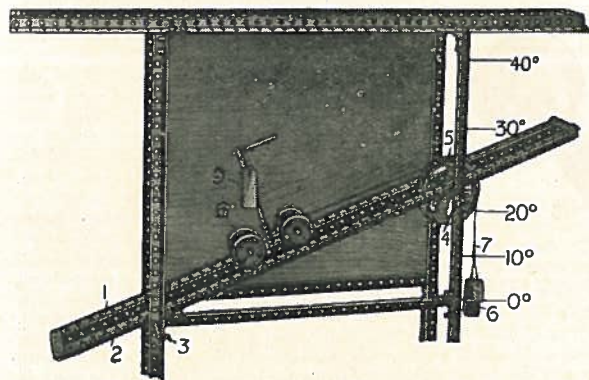

This is one of many interesting and important mechanical principles that may be demonstrated with Meccano. The force required to raise a body up an inclined plane varies according to the angle of the slope, and to the amount of friction of the body upon the plane. In the example illustrated, the load to be moved is mounted on wheels and runs upon a smooth surface, with the result that the amount of friction to be overcome is very small indeed.

The plane is made of two Angle Girders 1, 2, connected together at each end by  $2\frac{1}{2}$ " Strips and carried on a Rod 3 passed through holes in the vertical girders of the frame and in the girders forming the plane. The other end of the plane rests on a Rod 4 which carries a 3" Pulley Wheel 5. By placing the Rod

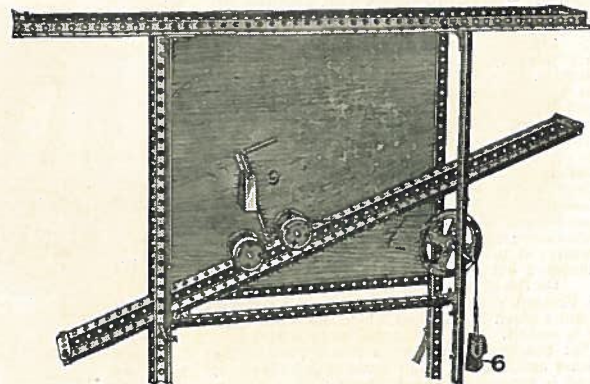

4 through different holes in the side girders the slope or angle of the inclined plane may be varied. To obviate the need of a protractor to ascertain the slope of the plane, it may be stated that if the Rod 4 be placed in the fourth hole of the vertical girders, with the plane pivotally mounted on Rod 3 (as shown in the illustration), the surface of the plane will represent an incline of  $10^\circ$ . If placed in the 9th hole,  $20^\circ$ . If in the 15th hole  $30^\circ$ , and if in the 21st hole  $40^\circ$ . The force or weight 6 on the cord 7 is directed over the Pulley 5 in a line parallel to the plane, and the cord is connected to the carriage. The axles of the carriage wheels are journaled in Couplings bolted to either end of a 2" Rod.

Before commencing the experiment, weights should be hung on the cord 7, which are just sufficient to maintain the carriage 6 in equilibrium. If a weight 9 be then hung on the carriage it should be noted what additional weight is required to be hung on the end of the cord 7 just to make the carriage slowly ascend the plane. The weight 9 should then be varied and the alteration in the weight 6 on the cord 7 to make the carriage ascend the plane noted, and these results should be tabulated.

The second example illustrated above shows the line of force acting along the cord 7 in a horizontal position instead of parallel to the inclined plane. Having exactly balanced the carriage as before, different loads should be placed on the carriage at 9 and notes made of the additional weights at 6 necessary to cause the carriage to begin to move up the plane. These results should also be tabulated.

In every case it will be found that a small force at 6 will overcome a greater one at 9. The power required to raise a given load may be ascertained by the aid of the principle of energy (see Section III, page 5), and a consideration of this principle will also explain the mechanical advantage obtained from the inclined plane. For the purpose of this experiment we will assume that a weight of 150 grammes has been attached to the carriage at 9. If the carriage is moved from the point 3 to the point 4, on reaching the latter it will have risen vertically through a space of approximately 5", but it can only have done so by travelling *longitudinally* through a distance of 15"; therefore to raise the carriage 5", the force 6 descends through three times that distance (i.e., 15"). Hence, 50 grammes attached to the power hook at 6 will be sufficient to raise 150 grammes at 9 (ignoring friction), since the number of units of energy exerted by the force is three times greater than that produced by the load.

The inclined plane is usually employed as a mechanical power in the form of a wedge or a screw (see Section IX, Screw Mechanism). The tremendous increase of power derived from the use of screw-gear forms an interesting illustration of the principle of the inclined plane, and Meccano boys may build some very instructive models, on the lines of that described above, to demonstrate the advantages so obtained.

## STRIPS, GIRDERS AND BRACKETS

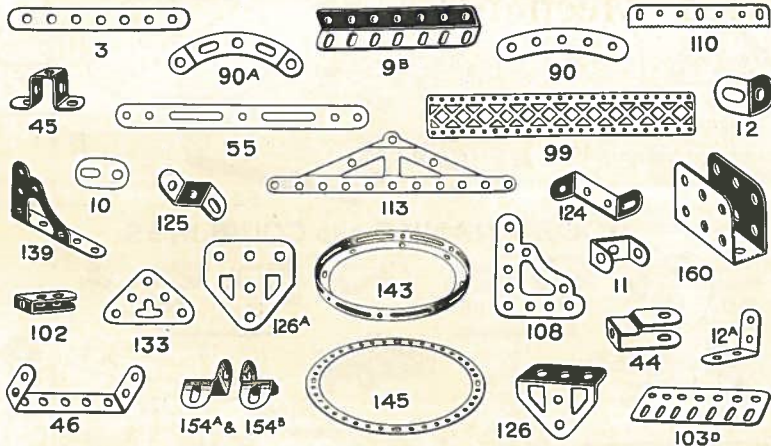

## WHEELS, GEARS ETC

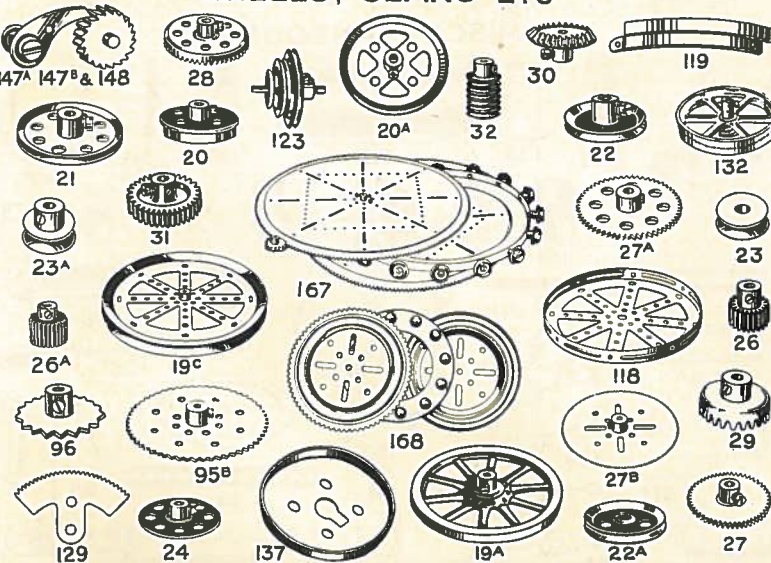

## Particulars and Prices of Meccano Parts

| No.  | Perforated Strips                      | Price | No.  | Perforated Strips   | Price | No.  | Spring Clips                               | Price |
|------|--|-------|------|---------------------|-------|------|--|-------|
| 1.   | 12 1/2" 1/2 doz.                       | 30    | 3.   | 3 1/2" ... 1/2 doz. | 10    | 35.  | Spring Clips                               | 15    |
| 1a.  | 9 1/2" "                               | 25    | 4.   | 3" ... "            | 10    | 36.  | Screw Drivers                              | 10    |
| 1b.  | 7 1/2" "                               | 20    | 5.   | 2 1/2" ... "        | 06    | 36a. | Screw Drivers, Extra Long                  | 25    |
| 2.   | 5 1/2" "                               | 15    | 6.   | 2" ... "            | 06    | 37.  | Nuts and Bolts, 7/32"                      | 15    |
| 2a.  | 4 1/2" "                               | 10    | 6a.  | 1 1/2" ... "        | 06    | 37a. | Nuts                                       | 05    |
|      |  |       |      |                     |       | 37b. | Bolts, 7/32"                               | 10    |
|      |  |       |      |                     |       | 38.  | Washers                                    | 05    |
| 7.   | 2 1/4" each                            | 25    | 9a.  | 4 1/2" ... 1/2 doz. | 30    | 40.  | Hanks of Cord                              | 05    |
| 7a.  | 1 1/8" "                               | 20    | 9b.  | 3 1/2" ... "        | 30    | 41.  | Propeller Blades                           | 15    |
| 8.   | 1 1/2" 1/2 doz.                        | 50    | 9c.  | 3" ... "            | 30    | 43.  | Springs                                    | 05    |
| 8a.  | 9 1/2" "                               | 45    | 9d.  | 2 1/2" ... "        | 25    | 44.  | Cranked Bent Strips                        | 03    |
| 8b.  | 7 1/2" "                               | 40    | 9e.  | 2" ... "            | 25    | 45.  | Double                                     | 03    |
| 9.   | 5 1/2" "                               | 35    | 9f.  | 1 1/2" ... "        | 25    | 46.  | Double Angle Strips, 2 1/4" x 1"           | 20    |
| 10.  | Flat Brackets                          | 05    |      |                     |       | 47.  | " " " " 2 1/4" x 1 1/4"                    | 30    |
| 11.  | Double Brackets                        | 03    |      |                     |       | 47a. | " " " " 3" x 1 1/4"                        | 35    |
| 12.  | Angle Brackets, 1 1/2" x 1"            | 10    |      |                     |       | 48.  | " " " " 1 1/2" x 1 1/4"                    | 15    |
| 12a. | " " " 1 1/2" x 1"                      | 15    |      |                     |       | 48a. | " " " " 2 1/4" x 1 1/4"                    | 15    |
| 12b. | " " " 1" x 1"                          | 10    |      |                     |       | 48b. | " " " " 3 1/4" x 1 1/4"                    | 20    |
|      |  |       |      |                     |       | 48c. | " " " " 4 1/4" x 1 1/4"                    | 30    |
| 13.  | 1 1/8" each                            | 05    | 16a. | 2 1/2" ... 2 for    | 02    | 48d. | " " " " 5 1/4" x 1 1/4"                    | 30    |
| 13a. | 8" "                                   | 05    | 16b. | 3" ... "            | 03    | 50a. | Eye Pieces, with boss                      | 15    |
| 14.  | 6 1/2" "                               | 04    | 17.  | 2" ... 3 for        | 03    | 52.  | Perforated Flanged Plates, 5 1/2" x 2 1/4" | 20    |
| 15.  | 5" "                                   | 03    | 18a. | 1 1/2" ... "        | 02    | 52a. | Flat Plates, 5 1/2" x 3 1/2"               | 15    |
| 16.  | 3 1/2" 2 for                           | 05    | 18b. | 1" ... "            | 02    | 53.  | Perforated Flanged Plates, 3 1/2" x 2 1/4" | 15    |
| 17.  | "                                      | 04    |      |                     |       | 53a. | Flat Plates, 4 1/2" x 2 1/4"               | 12    |
| 19.  | Crank Handles, Large                   | 10    |      |                     |       | 54.  | Perforated Flanged Sector Plates           | 15    |
| 19a. | Wheels, 3" diam., with set screws      | 45    |      |                     |       | 55.  | Perforated Strips, slotted, 5 1/2" long    | 05    |
| 20.  | Flanged Wheels, 1 1/2" diam.           | 20    |      |                     |       | 55a. | " " " " 2" "                               | 03    |
| 20b. | " " Pulley Wheels                      | 15    |      |                     |       |      |  |       |
| 19b. | 3" dia. with centre boss and set screw | 25    |      |                     |       | 56a. | Instruction Manuals, No. 00-3x             | 50    |
| 19c. | 6" "                                   | 20    |      |                     |       | 56b. | " " " No. 4x-6x                            | 75    |
| 20a. | 2" "                                   | 10    |      |                     |       | 56c. | " " " No. 00                               | 15    |
| 21.  | 1 1/2" "                               | 15    |      |                     |       | 58d. | Meccano Standard Mechanisms Manual         | 50    |
| 22.  | 1" "                                   | 10    |      |                     |       |      |  |       |
| 23a. | 1 1/2" " without                       | 10    |      |                     |       | 57.  | HOOKS                                      | 01    |
| 22a. | 1" " "                                 | 05    |      |                     |       | 57a. | " Scientific                               | 02    |
| 23.  | 1 1/2" " "                             | 15    |      |                     |       | 57b. | " Loaded                                   | 15    |
| 24.  | Bush Wheels                            | 20    |      |                     |       | 58.  | Spring Cord                                | 30    |
| 25.  | Pinion Wheels, 1/2" diam.              | 15    |      |                     |       | 59.  | Collars with Set Screws                    | 05    |
| 25a. | " " double width                       | 30    |      |                     |       | 61.  | Windmill Sails                             | 25    |
| 26.  | " " 1/2" " "                           | 15    |      |                     |       | 62.  | Cranks                                     | 10    |
| 26a. | " " double width                       | 25    |      |                     |       | 62a. | Threaded Cranks                            | 12    |
|      |  |       |      |                     |       | 62b. | Double Arm Cranks                          | 10    |
|      |  |       |      |                     |       | 63.  | Couplings                                  | 15    |
|      |  |       |      |                     |       | 63a. | Octagonal Couplings                        | 20    |
|      |  |       |      |                     |       | 63b. | Strip Couplings                            | 20    |
|      |  |       |      |                     |       | 63c. | Threaded Couplings                         | 20    |
|      |  |       |      |                     |       | 64.  | Threaded Bosses                            | 06    |
|      |  |       |      |                     |       | 65.  | Centre Forks                               | 05    |
|      |  |       |      |                     |       | 66.  | Weights, 50 grammes                        | 20    |
|      |  |       |      |                     |       | 67.  | " 25                                       | 15    |
|      |  |       |      |                     |       | 68.  | Wood screws, 1/4"                          | 10    |
|      |  |       |      |                     |       | 69.  | Set Screws                                 | 10    |
|      |  |       |      |                     |       | 69a. | Grub Screws, 5/32"                         | 10    |
|      |  |       |      |                     |       | 69b. | " 7/32"                                    | 10    |
|      |  |       |      |                     |       | 70.  | Flat Plates, 5 1/2" x 2 1/4"               | 15    |
|      |  |       |      |                     |       | 72.  | " 2 1/4" x 2 1/4"                          | 10    |
|      |  |       |      |                     |       | 76.  | Triangular Plates, 2 1/4"                  | 05    |
|      |  |       |      |                     |       | 77.  | " " 1"                                     | 04    |
| 27.  | 50 teeth to gear with 1/2" pinion      | 20    |      |                     |       |      |  |       |
| 27a. | 57 " "                                 | 20    |      |                     |       |      |  |       |
| 27b. | 133 " " (3 1/2" diam.)                 | 65    |      |                     |       |      |  |       |
| 28.  | Contrate Wheels, 1 1/2" diam.          | 30    |      |                     |       |      |  |       |
| 29.  | " " 1 1/4" diam.                       | 20    |      |                     |       |      |  |       |
| 30.  | Bevel Gears, 1/2", 26 teeth            | 30    |      |                     |       |      |  |       |
| 30a. | " " 1 1/2", 16 " } Can only be,        | 25    |      |                     |       |      |  |       |
| 30c. | " " 1 1/8", 48 " } used together,      | 65    |      |                     |       |      |  |       |
| 31.  | Gear Wheels, 1", 38                    | 40    |      |                     |       |      |  |       |
| 32.  | Worm Wheels                            | 20    |      |                     |       |      |  |       |
| 34.  | Spanners                               | 05    |      |                     |       |      |  |       |
| 34b. | Box Spanners                           | 20    |      |                     |       |      |  |       |



# Particulars and Prices of Meccano Parts (continued)

| No.   |  | \$                 | No.   |   | \$           |     |
|-------|--|--------------------|-------|---|--------------|-----|
| 78.   | 11 1/2" each   | .25                | 123.  | Cone Pulleys ... ..                               | each .50     |     |
| 79.   | 8" "   | .15                | 124.  | Reversed Angle Brackets, 1 1/2" "                 | 1/2 doz. .15 |     |
| 79a.  | 6" "   | .10                | 125.  | " "   | 1/2" "       | .10 |
| 80.   | 5" "   | .10                | 126.  | Trunnions " " " "                                 | each .08     |     |
| 80.   | 5 1/2" Curved Strips, 10" radius                             | .05                | 126a. | Flat Trunnions " " " "                            | each .05     |     |
| 89a.  | 3" " cranked, 1 1/2" radius, 4 to circle                     | .05                | 127.  | Simple Bell Cranks " " " "                        | .05          |     |
| 90.   | 2 1/2" " " 2 1/2" radius ... 1/2 doz.                        | .25                | 128.  | Boss Bell Cranks " " " "                          | .10          |     |
| 90a.  | 2 1/2" " " cranked, 1 1/2" radius, 4 to circle               | .25                | 129.  | Rack Segments, 3" diam.                           | .20          |     |
| 94.   | Sprocket Chain ... ..  | per 40" length .25 | 130.  | Triple Throw Eccentrics " " " "                   | .10          |     |
| *95a. | Sprocket Wheels, 2" diam. ... ..                             | each .20           | 131.  | Dredger Buckets " " " "                           | .10          |     |
| *95b. | " " 3 1/2" " " " "   | .30                | 132.  | Flywheels, 2 3/4" diam. ... ..                    | .75          |     |
| *96.  | " " 3" " " " "   | .10                | 133.  | Corner Brackets " " " "                           | .05          |     |
| *96a. | " " 3" " " " "   | .10                | 134.  | Crank Shafts, 1" stroke " " " "                   | .05          |     |
| 97.   | Braced Girders, 3 1/2" long ... ..                           | 1/2 doz. .20       | 135.  | Theodolite Protractors " " " "                    | .06          |     |
| 97a.  | " " 3" " " " "   | .18                | 136.  | Handrail Supports " " " "                         | .10          |     |
| 98.   | " " 2 1/2" " " " "   | .15                | 137.  | Wheel Flanges " " " "                             | .15          |     |
| 99.   | " " 12 1/2" " " " "  | .75                | 138.  | Ship's Funnels " " " "                            | .15          |     |
| 99a.  | " " 9 1/2" " " " "   | .60                | 138a. | " " Cunard type " " " "                           | .25          |     |
| 99b.  | " " 7 1/2" " " " "   | .55                | 139.  | Flanged Brackets (right) " " " "                  | .10          |     |
| 100.  | " " 5 1/2" " " " "   | .50                | 139a. | " (left) " " " "                                  | .10          |     |
| 100a. | " " 4 1/2" " " " "   | .35                | 140.  | Universal Couplings " " " "                       | .30          |     |
| 101.  | Healds, for looms ... ..                                     | doz. .30           | 141.  | Wire Lines (for suspending clock weights) " " " " | .15          |     |
| 102.  | Single Bent Strips " " " "                                   | each .05           | 142.  | Rubber Rings, 3" rim " " " "                      | .10          |     |
| 103.  | Flat Girders, 5 1/2" long ... ..                             | 1/2 doz. .25       | 143.  | Circular Girders, 5 1/4" diam. ... ..             | .55          |     |
| 103a. | " " 9 1/2" " " " "   | .35                | 144.  | Dog Clutches " " " "                              | .30          |     |
| 103b. | " " 12 1/2" " " " "  | .40                | 145.  | Circular Strips, 7" diam. over all " " " "        | .50          |     |
| 103c. | " " 4 1/2" " " " "   | .25                | 146.  | " Plates, 6" " " " "                              | .60          |     |
| 103d. | " " 3" " " " "   | .25                | 147a. | Pawls " " " " " "                                 | .06          |     |
| 103e. | " " 3 1/2" " " " "   | .20                | 147b. | Pivot Bolt with 2 nuts " " " "                    | .06          |     |
| 103f. | " " 2 1/2" " " " "   | .20                | 148.  | Ratchet Wheels " " " "                            | .30          |     |
| 103g. | " " 2" " " " "   | .15                | 150.  | Crane Grabs " " " "                               | .25          |     |
| 103h. | " " 1 1/2" " " " "   | .15                | 151.  | Pulley Blocks, Single Sheave " " " "              | .25          |     |
| 103i. | " " 7 1/2" " " " "   | .30                | 152.  | " " Two " " " "                                   | .35          |     |
| 104.  | Shuttles, for looms ... ..                                   | each 1.20          | 153.  | " " Three " " " "                                 | .50          |     |
| 105.  | Reed Hooks, for looms ... ..                                 | .10                | 154a. | Corner Angle Brackets, 1 1/2", right hand " " " " | .25          |     |
| 106.  | Wood Rollers " " " "   | .40                | 154b. | Corner Angle Brackets, 1 1/2", left hand " " " "  | .25          |     |
| 106a. | Sand Rollers " " " "   | .45                | 155.  | Rubber Rings, 1/2" " " " "                        | each .03     |     |
| 107.  | Tables for Designing Machines " " " "                        | .25                | 156.  | Pointers, 2 1/2" over all, with boss... ..        | .15          |     |
| 108.  | Architraves " " " "  | .07                | 157.  | Fans, 2" diam. " " " "                            | .15          |     |
| 109.  | Face Plates, 2 1/2" diam. " " " "                            | .15                | 159.  | Circular Saws " " " "                             | .50          |     |
| 110.  | Rack Strips, 3 1/2" " " " "                                  | .10                | 160.  | Channel Bearings, 1 1/2" x 1" x 1/2" " " " "      | .15          |     |
| 111.  | Bolts, 1/2" " " " "  | .02                | 162.  | Boiler, complete with ends " " " "                | .50          |     |
| 111a. | " " 1/2" " " 2 for " " " "                                   | .03                | 162a. | Boiler ends " " " "                               | .12          |     |
| 111c. | " " " " " doz. " " " "                                       | .15                | 163.  | Sleeve Pieces " " " " pair " " " "                | .15          |     |
| 113.  | Girder Frames " " " " each " " " "                           | .10                | 164.  | Chimney Adaptors " " " " each " " " "             | .15          |     |
| 114.  | Hinges " " " " per pair " " " "                              | .20                | 165.  | Swivel Bearings " " " " " " " "                   | .25          |     |
| 115.  | Threaded Pins " " " " each " " " "                           | .05                | 166.  | End " " " " " " " "                               | .15          |     |
| 116.  | Fork Pieces, Large " " " " " " " "                           | .10                | 167.  | Geared Roller Bearings " " " " " " " "            | 12.50        |     |
| 116a. | " " Small " " " " " " " "                                    | .10                | 167a. | Roller Races, geared, 192 teeth " " " "           | 3.00         |     |
| 117.  | Steel Balls, 3/8" diam. " " " " " " " "                      | .02                | 167b. | Ring Frames for Rollers " " " " " " " "           | 2.00         |     |
| 118.  | Hub Disc, 5 1/2" diam. " " " " " " " "                       | .50                | 167c. | Pinions for Roller Bearings, 16 teeth " " " "     | .75          |     |
| 119.  | Channel Segments (8 to circle, 1 1/2" diam.) " " " " " " " " | .15                | 168.  | Ball Bearings, 4" diam. " " " " " " " "           | 3.00         |     |
| 122.  | Miniature Loaded Sacks " " " " " " " "                       | .05                | 168a. | Ball Races, flanged " " " " " " " "               | .50          |     |
|       |  |                    | 168b. | " " geared " " " " " " " "                        | .75          |     |
|       |  |                    | 168c. | Ball Casings, complete with balls " " " "         | 1.75         |     |
|       |  |                    | 169.  | Digger Buckets " " " " " " " "                    | .75          |     |
|       |  |                    | 170.  | Eccentrics, 1/2" throw " " " " " " " "            | .30          |     |



# INDEX

| Description.                                       | Page.         | S.M. No.      |
|--|---------------|---------------|
| Ackermann Steering Gear ...                        | 26 ...        | 115           |
| Adjusting Devices ...                              | 29 and 30 ... | 135, 136      |
| Adjustment, Screw ...                              | 30 ...        | 138, 139      |
| Automatic Brake or Reverse Device ...              | 42 ...        | 278           |
| Bearings, Ball ...                                 | 25 ...        | 104, 105      |
| " Knife-edge ...                                   | 24 ...        | 102           |
| " Reinforced ...                                   | 24 ...        | 103           |
| " Roller ...                                       | 23 to 25 ...  | 101, 106      |
| Bell Crank ...                                     | 39 ...        | 267           |
| Belt Clutch ...                                    | 4 ...         | 18a           |
| " Reversing Gear ...                               | 4 ...         | 18            |
| " and Rope Mechanism ...                           | 4 ...         | 15-20         |
| Brake, Screw-operated Double Band ...              | 22 ...        | 86            |
| " Strap and Lever ...                              | 21 ...        | 81, 83        |
| " Strap and Screw ...                              | 22 ...        | 85            |
| " Strap and Weighted Lever ...                     | 21 ...        | 82            |
| Bucket for Excavator ...                           | 35 ...        | 183           |
| Cams, or Tappets ...                               | 39 ...        | 264, 266      |
| Centrifugal Governor ...                           | 22 ...        | 87            |
| Clock Escapement ...                               | 22 ...        | 88, 88a       |
| Clutch ...   | 16 ...        | 62            |
| " Belt ...   | 4 ...         | 18a           |
| " Dog ...  | 16 ...        | 61, 63        |
| Conveyor, Bucket ...                               | 35 ...        | 182           |
| Crankshaft, built-up ...                           | 41 ...        | 274           |
| Crank Stroke, to increase length of ...            | 43 ...        | 280           |
| Crosshead ...                                      | 41 ...        | 275           |
| Differential Gear ...                              | 36 ...        | 251           |
| Discharge, Automatic ...                           | 31 ...        | 152           |
| Dredging Apparatus, Bucket Drive-changing Gear ... | 17 to 20 ...  | 64, 65, 67-72 |
| Drive Transmission for Steam Locomotive ...        | 42 ...        | 277           |
| Endless Rope Traversing Gear ...                   | 34 ...        | 169           |
| Energy, meaning of ...                             | 5 ...         | —             |
| Epi-cycloidal Gear ...                             | 39 ...        | 268           |
| Escapement, Clock ...                              | 22 ...        | 88, 88a       |
| Flexible Coupling (Universal Joint) ...            | 40 ...        | 272           |
| Friction in Pulleys ...                            | 5, 7 ...      | Ex. 6         |
| Gear, Bevel ...                                    | 3 ...         | 4             |
| " Chain ...  | 3 ...         | 7             |
| " Contrate ...                                     | 3 ...         | 3, 6          |
| " Ratios ...                                       | 3 ...         | 1-7           |
| " Worm ...   | 3 ...         | 5             |
| Grab ...   | 35 ...        | 184           |

| Description.                                     | Page.         | S.M. No.       |
|--|---------------|----------------|
| Handles, Examples of Meccano Hoist, Chain ...    | 38 ...        | 255-259 etc.   |
| " ...  | 31 ...        | 153            |
| Hoisting-gear, driven by Screw Mechanism ...     | 29 ...        | 133            |
| Inclined Plane ...                               | 44 ...        | —              |
| Intermittent Motion ...                          | 39 ...        | 264-266        |
| Jib-raising Gear, Screw-operated ...             | 28 and 29 ... | 131, 134       |
| Knife-edge Bearing ...                           | 24 ...        | 102            |
| Lever, First Order ...                           | 11 ...        | Fig. 15        |
| " Second Order ...                               | 12 ...        | " 16           |
| " Third Order ...                                | 13 ...        | Fig. 17        |
| " Adapted to Meccano Models ...                  | 14 and 15 ... | Figs. 18-23    |
| " fitted to Motor Chassis in Platform Scales ... | 15 ...        | 52             |
| " ...  | 14 ...        | 51             |
| Locking Devices ...                              | 30 ...        | 136, 137       |
| Lock-nuts, Bolt and ...                          | 38 ...        | 263            |
| Measurement of Angles ...                        | 39 ...        | 269            |
| Multiple-drive Mechanism ...                     | 40 ...        | 271            |
| Oscillating Cylinders ...                        | 41 ...        | 276            |
| Overhead Travellers for Gantries ...             | 31 and 32 ... | 151, 154-156   |
| Overhead Trolley, Drive-changing Gear for ...    | 18 ...        | 68             |
| Overhead Trolley, with Chain Hoist ...           | 31 ...        | 153            |
| Pawl and Ratchet Gear ...                        | 21 and 37 ... | 84, 254a       |
| Pedestal ...                                     | 38 ...        | 260            |
| Pivot, formed from Bolt and Nuts ...             | 38 ...        | 262, 263       |
| Pulley Blocks, pivoted to Jib ...                | 9 ...         | 37             |
| " " Three-sheave ...                             | 7 and 9 ...   | Fig. 4, 31, 36 |
| " " Two-sheave ...                               | 6 and 9 ...   | Ex. 3, 32      |
| " " Variable ...                                 | 10 ...        | 41             |
| " " Weston's ...                                 | 7 ...         | Ex. 6          |
| Pulleys, Deep-grooved (single sheave) ...        | 10 ...        | 39a            |
| " Deep-grooved (double sheave) ...               | 32 ...        | 155            |
| " Friction in ...                                | 5 ...         | —              |
| " Guide ...                                      | 10 ...        | 39, 40         |
| " Separate Cord System ...                       | 7 ...         | Ex. 5          |
| " Single Fixed ...                               | 5 ...         | Ex. 1          |

| Description.   | Page.             | S.M. No.          |
|--|-------------------|-------------------|
| Pulleys, Single Movable ...  | 5, 9, and 10 ...  | Ex. 2, 33, 35, 38 |
| " in Stiff-Leg Derrick ...   | 6 ...             | Ex. 4             |
| Protractor, the Meccano ...  | 39 ...            | 269               |
| Quick-Return Motion ...  | 38 ...            | 261               |
| Rack and Pinion Traversing Mechanism ...   | 33 ...            | 166               |
| Reciprocating Engine Mechanism ...   | 41 ...            | 274-276           |
| " Motion ...   | 34, 36 and 39 ... | 171, 252, 264     |
| Retarding Appliances—see Section VI.   |                   |                   |
| Relation of Power to the Load, in Levers ...   | 11 ...            | Ex. 3             |
| Relation of Power to the Load, in Pulleys ...  | 5, 6 ...          | Ex. 2, 3, etc.    |
| Reversing Gear ...   | 17 and 18 ...     | 64-66             |
| " (Belt) ...   | 4 ...             | 17, 18            |
| Roller Bearings ...  | 23 and 25 ...     | 101, 106          |
| Screw Gear ...   | 22 and 28-30 ...  | 85, 86, 131-139   |
| Shovel for Giant Excavator ...   | 35 ...            | 181               |
| Speed Indicator ...  | 40 ...            | 273               |
| Spring, Laminated ...  | 36 ...            | 253               |
| " Suspension ...   | 26 ...            | 115               |
| Steering Gear ...  | 26 and 27 ...     | 115-119           |
| " Worm and Pinion ...  | 26 ...            | 116               |
| Sun and Planet Mechanism ...   | 43 ...            | 281               |
| Tappets—see Cams   |                   |                   |
| Torque Converter, the Constantinesco ...   | 37 ...            | 254               |
| Transmission of Motive Power to Road Wheels ...  | 34 ...            | 170               |
| Travellers, Overhead, for Gantries ...   | 31 and 32 ...     | 151, 154-156      |
| Travelling Carriage, Self-hauled Travelling Models, Application of Brakes and Reverse in ... | 34 ...            | 168               |
| " ...  | 42 ...            | 278               |
| Traversing Mechanism ...   | 33 and 34 ...     | 165-171           |
| " application ...  | 28 ...            | 132               |
| Truck, with Automatic Discharge ...  | 31 ...            | 152               |
| Universal Joint, or Coupling ...   | 40 ...            | 272               |
| Valve Gear, Walschaert's ...   | 42 ...            | 277               |
| Variable Rotary Drive ...  | 40 ...            | 270               |
| " Speed ...  | 37 ...            | 254               |
| Winding Gear for Cranes or Derricks ...  | 43 ...            | 279               |
| Worm Gear ...  | 3 ...             | 5                 |

# **HORNBY** MECHANICAL **TRAINS**

These splendid trains are manufactured by Meccano Company Inc., and they are made from the finest materials obtainable. Each train is a beautiful piece of workmanship with perfect mechanism.

For the boy who takes an intelligent interest in railway engineering—and there must be very few boys nowadays who do not—Hornby Trains have an irresistible appeal. He finds in them those qualities for which he has waited so long, and he knows that no pains have been spared in their construction to make them as realistic and accurate as possible.

Hornby Trains represent the most advanced type of trains. They have locomotives of pressed steel instead of cast iron and with their rich colouring, beautiful finish and realistic appearance they are certain to give the utmost satisfaction. All Hornby Locos are carefully tested before leaving the factory and their efficiency is guaranteed.

The Spring Motor that operates the locomotive in each case is the most efficient ever produced, powerful, speedy and fitted with accurately cut gears that ensure smooth running.

## **ASK YOUR DEALER FOR AN ILLUSTRATED PRICE LIST OF THE HORNBY MECHANICAL TRAINS**

**HORNBY TRAIN SET No. M1.** This set consists of Locomotive, Tender and two Cars with ten sections of track. The locomotive is coloured red and black with gold trimmings and the cars are coloured green and gold. The set is packed in an attractive carton.

**HORNBY TRAIN SET No. M2.** The contents of this set are the same as those in the No. 1 set but the finish of the components is different. The locomotives are coloured green and gold and the cars are coloured yellow and black.

**HORNBY TRAIN SET No. M3.** This is a new Freight Train consisting of Locomotive, Tender, Box Car, Tank Car and Caboose, with twelve sections of track. The various components are beautifully coloured and finished.

**YOUR DEALER WILL BE PLEASED TO SHOW YOU THESE TRAINS**

# INDEX

| Description.  | Page.     | S.M. No.      |
|---|-----------|---------------|
| Adjusting Devices ... ..                              | 29 and 30 | 135, 136      |
| Adjustment, Screw ... ..                              | 30        | 138, 139      |
| Automatic Brake or Reverse Device ... ..              | 42        | 278           |
| Bearings, Ball ... ..                                 | 25        | 104, 105      |
| " Knife-edge ... ..                                   | 24        | 102           |
| " Reinforced ... ..                                   | 24        | 103           |
| " Roller ... ..                                       | 23 to 25  | 101, 106      |
| Bell Crank ... ..                                     | 39        | 267           |
| Belt Clutch ... ..                                    | 4         | 18a           |
| " Reversing Gear ... ..                               | 4         | 18            |
| " and Rope Mechanism ... ..                           | 4         | 15-20         |
| Brake, Screw-operated Double Band ... ..              | 22        | 86            |
| " Strap and Lever ... ..                              | 21        | 81, 83        |
| " Strap and Screw ... ..                              | 22        | 85            |
| " Strap and Weighted Lever ... ..                     | 21        | 82            |
| Bucket for Dragline Excavator ... ..                  | 35        | 183           |
| Cams, or Tappets ... ..                               | 39        | 264, 266      |
| Centrifugal Governor... ..                            | 22        | 87            |
| Clock Escapement ... ..                               | 22        | 88, 88a       |
| Clutch ... ..   | 16        | 62            |
| " Belt ... ..   | 4         | 18a           |
| " Dog ... ..  | 16        | 61, 63        |
| Conveyor, Bucket ... ..                               | 35        | 182           |
| Crankshaft, built-up ... ..                           | 41        | 274           |
| Crosshead ... ..                                      | 41        | 275           |
| Differential Gear ... ..                              | 36        | 251           |
| Discharge, Automatic ... ..                           | 31        | 152           |
| Dredging Apparatus, Bucket Drive-changing Gear ... .. | 17 to 20  | 64, 65, 67-72 |
| Drive Transmission for Steam Locomotive ... ..        | 42        | 277           |
| Endless Rope Traversing Gear ... ..                   | 34        | 169           |
| Energy, meaning of ... ..                             | 5         | —             |
| Epi-cycloidal Gear ... ..                             | 39        | 268           |
| Escapement, Clock ... ..                              | 22        | 88, 88a       |
| Flexible Coupling (Universal Joint) ... ..            | 40        | 272           |
| Friction in Pulleys ... ..                            | 5, 7      | Ex. 6         |
| Gear, Bevel ... ..                                    | 3         | 4             |
| " Chain ... ..  | 3         | 7             |
| " Contrate ... ..                                     | 3         | 3, 6          |
| " Ratios ... ..                                       | 3         | 1-7           |
| " Worm ... ..   | 3         | 5             |
| Grab ... ..   | 35        | 184           |

| Description.  | Page.     | S.M. No.       |
|---|-----------|----------------|
| Handles, Examples of Meccano Hoist, Chain ... ..    | 38        | 255, 259 etc.  |
| " ... ..  | 31        | 153            |
| Hoisting-gear, driven by Screw Mechanism ... ..     | 29        | 133            |
| Inclined Plane ... ..                               | 44        | Ex. 2          |
| Intermittent Motion ... ..                          | 39        | 264-266        |
| Jib-raising Gear, Screw-operated ... ..             | 28 and 29 | 131, 134       |
| Knife-edge Bearing ... ..                           | 24        | 102            |
| Lever, First Order ... ..                           | 11        | Fig. 15        |
| " Second Order ... ..                               | 12        | 16             |
| " Third Order ... ..                                | 13        | Fig. 17        |
| " Adapted to Meccano Models ... ..                  | 14 and 15 | Figs. 18-23    |
| " fitted to Motor Chassis in Platform Scales ... .. | 15        | 52             |
| " ... ..  | 14        | 51             |
| Locking Devices ... ..                              | 30        | 136, 137       |
| Lock-nuts, Bolt and ... ..                          | 38        | 263            |
| Measurement of Angles ... ..                        | 39        | 269            |
| Multiple-drive Mechanism ... ..                     | 40        | 271            |
| Oscillating Cylinders ... ..                        | 41        | 276            |
| Overhead Travellers for Gantries ... ..             | 31 and 32 | 151, 154-156   |
| Overhead Trolley, Drive-changing Gear for ... ..    | 18        | 68             |
| Overhead Trolley, with Chain Hoist ... ..           | 31        | 153            |
| Pawl and Ratchet Gear ... ..                        | 21 and 37 | 84, 254a       |
| Pedestal ... ..                                     | 38        | 260            |
| Pivot, formed from Bolt and Nuts ... ..             | 38        | 262, 263       |
| Pulley Blocks, pivoted to Jib-head ... ..           | 9         | 37             |
| Pulley Blocks, Three-sheave ... ..                  | 7 and 9   | Fig. 4, 31, 36 |
| " Two-sheave ... ..                                 | 6 and 9   | Ex. 3, 32      |
| " Variable ... ..                                   | 10        | 41             |
| " Weston's ... ..                                   | 7         | Ex. 6          |
| Pulleys, Deep-grooved (single sheave) ... ..        | 10        | 39a            |
| " Deep-grooved (double sheave) ... ..               | 32        | 155            |
| " Friction in ... ..                                | 5         | —              |
| " Guide ... ..                                      | 10        | 39, 40         |
| " Separate Cord System ... ..                       | 7         | Ex. 5          |
| " Single Fixed ... ..                               | 5         | Ex. 1          |

| Description.   | Page.         | S.M. No.          |
|--|---------------|-------------------|
| Pulleys, Single Moveable ... ..                                | 5, 9, and 10  | Ex. 2, 33, 35, 38 |
| " in Stiff-Leg Derrick ... ..                                  | 6             | Ex. 4             |
| Protractor, the Meccano ... ..                                 | 39            | 269               |
| Quick-Return Motion ... ..                                     | 38            | 261               |
| Rack and Pinion Traversing Mechanism ... ..                    | 33            | 166               |
| Reciprocating Engine Mechanism ... ..                          | 41            | 274-276           |
| " Motion ... ..  | 34, 36 and 39 | 171, 252, 264     |
| Retarding Appliances—see Section VI.                           |               |                   |
| Relation of Power to the Load, in Levers ... ..                | 11            | Ex. 3             |
| Relation of Power to the Load, in Pulleys ... ..               | 5, 6          | Ex. 2, 3, etc.    |
| Reversing Gear ... ..  | 17 and 18     | 64-66             |
| " (Belt) ... ..  | 4             | 17, 18            |
| Roller Bearings ... ..   | 23 and 25     | 101, 106          |
| Screw Gear ... ..  | 22 and 28-30  | 85, 86, 131-139   |
| Shovel for Giant Excavator ... ..                              | 35            | 181               |
| Speed Indicator ... ..   | 40            | 273               |
| Spring, Laminated ... ..                                       | 36            | 253               |
| " Suspension ... ..  | 26            | 115               |
| Steering Gear ... ..   | 26 and 27     | 115-119           |
| " " Worm and Pinion ... ..                                     | 26            | 116               |
| Tappets—see Cams   |               |                   |
| Torque Converter, the Constantinesco ... ..                    | 37            | 254               |
| Transmission of Motive Power to Road Wheels ... ..             | 34            | 170               |
| Travellers, Overhead, for Gantries ... ..                      | 31 and 32     | 151, 154-156      |
| Travelling Carriage, Self-hauled ... ..                        | 34            | 168               |
| Travelling Models, Application of Brakes and Reverse in ... .. | 42            | 278               |
| Traversing Mechanism ... ..                                    | 33 and 34     | 165-171           |
| " application of Screw Gear in, ... ..                         | 28            | 132               |
| Triangle of Forces ... ..                                      | 43            | Ex. No. 1         |
| Truck, with Automatic Discharge ... ..                         | 31            | 152               |
| Universal Joint, or Coupling ... ..                            | 40            | 272               |
| Valve Gear, Walschaert's ... ..                                | 42            | 277               |
| Variable Rotary Drive ... ..                                   | 40            | 270               |
| " Speed ... ..   | 37            | 254               |
| Worm Gear ... ..   | 3             | 5                 |

# Meccano Price List

## Meccano Outfits

|                            |                   |
|----------------------------|-------------------|
| No. 00 Meccano Outfit..... | \$ 1.00           |
| No. 1 " " .....            | 3.00              |
| No. 1x " " .....           | (with Motor) 5.00 |
| No. 2x " " .....           | " " 7.50          |
| No. 3x " " .....           | " " 12.50         |
| No. 4x " " .....           | " " 17.50         |
| No. 5x " " .....           | " " 30.00         |
| No. 6x " " .....           | " " 50.00         |

## Accessory Outfits

|  |                       |
|--|-----------------------|
| No. 00a Accessory Outfit.....                    | \$ 2.00               |
| (Converts a No. 00 Outfit into a No. 1 Outfit)   |                       |
| No. 1a Accessory Outfit.....                     | 3.00                  |
| (Converts a No. 1 Outfit into a No. 2x* Outfit)  |                       |
| No. 2a Accessory Outfit.....                     | 5.00                  |
| (Converts a No. 2x Outfit into a No. 3x Outfit)  |                       |
| No. 3a Accessory Outfit.....                     | 6.50                  |
| (Converts a No. 3x Outfit into a No. 4x Outfit)  |                       |
| No. 4a Accessory Outfit.....                     | 10.00                 |
| (Converts a No. 4x Outfit into a No. 5x† Outfit) |                       |
| No. 5a Accessory Outfit.....                     | 20.00                 |
| (Converts a No. 5x Outfit into a No. 6x Outfit)  |                       |
| * Except Motor.                                  | † Except Transformer. |

## Meccano Motors and Transformers

|  |        |
|--|--------|
| E.-2 Electric Motor (reversing) 6-8 volts..... | \$4.50 |
| E-3 " " " 110 " .....                          | 9.50   |

|   |        |
|---|--------|
| S-1 Meccano Spring Motor (reversing).....       | \$3.00 |
| Meccano Transformer (110 volts, 60c A. C.)..... | 2.50   |

## Hornby Mechanical Trains

**Set No. M-1.** Consists of locomotive, tender, and two Pullman cars, all beautifully lithographed in colors, with ten sections of track and necessary track connections. Colors: Locomotive, red and black with gold trimming. Cars, green and gold. Packed in an attractive cardboard box with rich lithographed label. Price.....\$3.75

**Set No. M-2.** Contents are the same as Set No. M-1, but

differently colored. Locomotive, green and black with gold trimming. Cars, yellow and black. Price.....\$3.75

**Set No. M-3.** Consists of locomotive, tender, box car, tank car and caboose, lithographed in colors, with 12 sections of track. Colors: Box car, yellow; tank car, red; caboose, brown; in attractive cardboard box. Price .....\$5.00

# MECCANO

Hornby's Original System, First Patented 1901

PATENTED IN THE UNITED STATES

|               |               |               |               |
|---------------|---------------|---------------|---------------|
| Jan. 16, 1906 | Jan. 4, 1916  | Oct. 24, 1916 | Oct. 19, 1920 |
| Nov. 18, 1913 | Feb. 15, 1916 | Oct. 9, 1917  | Dec. 14, 1920 |
| Nov. 23, 1915 | Aug. 1, 1916  | Dec. 24, 1918 | Apr. 11, 1922 |
| Dec. 21, 1915 | Aug. 29, 1916 | Feb. 11, 1919 | May 15, 1923  |

Design Patent July 4, 1916

PATENTED THROUGHOUT THE WORLD

## Meccano is more than a Toy

**I**T is important to remember that when a boy is playing with MECCANO he is using engineering parts in miniature, and that these parts act in precisely the same way as do the corresponding engineering elements in actual practice. No other system of model construction can be correct, and other toys which attempt the same object by other methods must avail themselves of constructive elements which are not correct engineering elements. Consequently, though a boy may succeed in building playthings with them, they are merely toys and nothing else.